

SABS STANDARDS DIVISION
Amendment No. 8 : March 2012
to
SANS 10142-1:2009 (ed. 1.7)
THE WIRING OF PREMISES
PART 1: LOW-VOLTAGE INSTALLATIONS

Approved in accordance with procedures of the SABS Standards Division.

Scope of amendment

This part of SANS 10142-1 has been amended to

- a) update referenced standards;
- b) add requirements for the installation of CFL lighting;
- c) introduce a label to be fitted to distribution boards to indicate the position of the earthing terminal for bonding of other services;
- d) add a warning related to the type and rating of replacement components of distribution boards;
- e) require that new, added or altered installations comply with this part of SANS 10142;
- f) change the requirements for voltage at available load; and
- g) apply changes to the test report.

Instructions for page replacement

Remove the following pages from your copy of SANS 10142-1:2009:

cover, 1-4, 15, 18(a), 23, 31-33, 62-71, 88, 136-137, 144, 157, 161, 169, 177-179, 186-187(b), 186-187(b), 191-202, 237, 246, 249, 253-254, 259-260, 269-280, 281-288, 324, 355-358.

SANS 10142-1:2009

Edition 1.7

Insert the following new pages attached:

cover, 1-4, 15, 18(a), 23, 31-33, 62, 62(a), 62(b), 63-71, 71(a), 71(b), 88, 136-137, 144, 157, 161-162, 169, 177-179, 186-187(b), 191-202, 237, 246, 249, 253-254, 259-260, 269-280, 280(a), 280(b), 281-286, 286(a), 286(b), 287-288, 288(a), 288(b), 324, 355-358.

© SABS

ISBN 978-0-626-26767-4

SANS 10142-1:2012

Edition 1.8

SOUTH AFRICAN NATIONAL STANDARD

The wiring of premises

Part 1: Low-voltage installations

Published by SABS Standards Division
1 Dr Lategan Road Groenkloof
✉ Private Bag X191 Pretoria 0001
Tel: +27 12 428 7911 Fax: +27 12 344 1568
www.sabs.co.za
© SABS

SABS

SANS 10142-1:2009

Edition 1.7

Table of changes

Change No.	Date	Scope
Amdt 1	Jan. 2003	Amended to change the number of the standard and the numbers of referenced standards, include a Regulator's Compliance Certificate (RCC) and specially tested assemblies (STA) as proof of compliance, clarify the requirements for distribution boards by adding definitions and a new annex (annex S), amend the requirements for surge protection, and change them to recommendations (included in annex L), amend the requirements for the bonding of antennas, delete the requirements for electric fences, change the requirements for extra low voltage lighting and delete the determination of earth resistance.
Tech corr. 1	March 2003	Changed to correct errors in the introduction, in 5.5.2 and in 6.6.1.21(a).
Amdt 2	Aug. 2003	Amended to remove the implementation date for proof of compliance of distribution boards.
Amdt 3	Dec. 2003	Amended to delete implementation requirements and references to specific national legislation from the normative part of the standard, rearrange the requirements for distribution boards, clarify the rating requirements for earth leakage units, add requirements for the connection of flexible cords and the indication of the position of the main switch, and to update normative references.

Table of changes (*continued*)

Change No.	Date	Scope
Amdt 4	April 2005	Amended to update and add normative references, to change table 4.2 in respect of circuit-breakers, conduit, switch-disconnectors, transformers and watt-hour meters, to clarify requirements for disconnection, bonding, earthing, and underfloor heating, and to change the requirements for installations in agricultural locations and at swimming pools.
Amdt 5	May 2006	Amended to exclude caravans from the scope of the standard, and to delete annex A, to update referenced standards for socket-outlets and stove couplers, to clarify the accessibility of live parts and distribution boards, and the requirements for open wiring, busbars, prospective short-circuit current, and voltage drop calculations, to add information on the applicability of the values in the current rating and voltage drop tables for cables, and conditions for conductors under screed, buried cables, and inaccessible joints, and to amend the requirements for underfloor heating, telecommunication d.c. power systems, and marking and labelling.
Amdt 6	2008	Amended to update referenced standards, to change requirements for busbar systems, surge protective devices (SPDs) and circuit-breakers, to modify requirements for medical locations, and to add requirements for the connection of generating sets and other alternative sources of supply to an electrical installation.

SANS 10142-1:2012

Edition 1.8

(As amended 2009 and 2012)

Table of changes (concluded)

Change No.	Date	Scope
Amdt 7	2009	Amended to change the current Certificate of Compliance (CoC) to a test report and to align references to the CoC in the text to refer to the test report.
Amdt 8	2012	Amended to update referenced standards, to add requirements for the installation of CFL lighting, to introduce a label to be fitted to distribution boards to indicate the position of the earthing terminal for bonding of other services, to add a warning related to the type and rating of replacement components of distribution boards, to require that new, added or altered installations comply with this part of SANS 10142, to change the requirements for voltage at available load, and to apply changes to the test report.

Foreword

This South African standard was approved by National Committee SABS SC 67F, *Electricity distribution systems and components – Installations*, in accordance with procedures of the SABS Standards Division, in compliance with annex 3 of the WTO/TBT agreement.

This document was approved in xxxxx 2012.

For new installations, this document supersedes SANS 10142-1:2009 (edition 1.7).

This edition is identified as edition 1.8 because it incorporates eight amendments. The number 1.8 appears only on the pages affected by amendment No. 8.

A vertical line in the margin shows where the text has been modified by the most recent change.

SANS 10142-1:2012
Edition 1.8
(As amended 2009 and 2012)

The test report in edition 1.7 will be valid in parallel with the test report in edition 1.8 for a period of 12 months from the date of publication of edition 1.7.

With the first edition of this part of SANS 10142, the standard was subdivided and now consists of the following parts, under the general title *The wiring of premises*:

Part 1: Low-voltage installations.

Part 2: Medium-voltage installations above 1 kV a.c. not exceeding 22 kV a.c. and up to and including 3 000 kW installed capacity.

Table 4.2 contains a list of the applicable standards for the components that may be installed in an electrical installation.

In the fourth edition of SANS 10142 (SANS 10142:1993), the design and installation requirements appeared in two separate clauses. However, because of the close link between these clauses, in edition 1 of SANS 10142-1 (SANS 0142-1:2001), the design and installation requirements were combined and are now given in clause 6 as installation requirements. The tables on cables and correction factors have been expanded extensively to align with the current cable specifications and relevant IEC standards. All the fundamental requirements have been grouped together with the safety requirements and are given in clause 5 as fundamental requirements. Special installations or locations are given in clause 7.

The clause on medical locations (see 7.7) has been extended and replaces SABS 051-2.

Information on national legislation that applies only in South Africa is given in text boxes in the Introduction (see pages 3(a) and 3(b)), in 8.1, 8.2.4 and in the test report (see page 281).

The updating of this part of SANS 10142 is the responsibility of a working group under the supervision of Committee SABS SC 67F, *Electricity distribution systems and components – Installations*.

To ensure that this part of SANS 10142 is always up to date, amendments will be introduced regularly. Each change made to the text as a result of an amendment is/will be indicated in the margin by the number of the amendment.

Annex L is normative where surge protection is required or installed. Annexes B, C, D, E, F, G, J, K, L, M, N, O, P, Q and R are for information only.

SANS 10142-1:2012

Edition 1.8

(As amended 2009 and 2012)

Introduction

In this edition an attempt has been made to move towards the IEC codes: extra low voltage (below 50 V) and d.c. applications (up to 1,5 kV) have been introduced as new requirements owing to the extensive usage of, and increased fire risk that result from, high load currents. This part of SANS 10142 does not intend to cover the LV control circuits of machinery or system components that are external circuits between separately installed parts of the machinery or system components.

This part of SANS 10142 includes certain provisions which are for information and guidance only. These provisions do not use the word "shall" and they can be found in the text, in the notes and in the informative annexes. Except in tables, notes are always for information only.

The aim of this part of SANS 10142 is to ensure that people, animals and property are protected from hazards that can arise from the operation of an electrical installation under both normal and fault conditions. An electrical installation has to provide protection against

- shock current,
- overcurrent,
- fault current,
- overvoltage,
- undervoltage,
- excessive temperatures, and
- electric arcs.

If any of the above arises, the protection should automatically disconnect the supply or limit currents and voltages to safe values. In the case of undervoltage, the protection should ensure that dangerous situations, due to the loss and restoration of supply (for example, to a motor), or due to a drop in voltage, cannot occur.

This part of SANS 10142 is concerned with ensuring the basic safety of electrical installations. To ensure the protection of people, animals and property and the proper functioning of an installation, the designer of an electrical installation should be aware of

- the characteristics of the power supply,
- the nature of the demand, and
- the operating environment of each part of the installation.

3(a)

SANS 10142-1:2012

Edition 1.8

(As amended 2009 and 2012)

It is especially important to be aware of the activities of occupants of a building. For example, the occupants might be engaged in wet processes or in the handling of flammable or explosive materials. These activities will influence the design of the installation. If a client wants more safety features for the installation than those prescribed in this part of SANS 10142, such features have to be included in the contract documentation.

The provisions of this part of SANS 10142 apply only to the selection and application of electrical equipment, appliances and accessories, which are part of the fixed electrical installation. They do not apply to the construction and safety of the equipment, appliances and accessories; those aspects are dealt with in other standards.

The Mine Health and Safety Act, 1996 (Act No. 29 of 1996), which is administered by the Chief Inspector of Mines of the Department of Minerals and Energy, requires that certain prescribed electrical installations on mines comply with the requirements of SANS 10142-1. It also requires that a competent person, as defined, will be responsible to ensure that those prescribed electrical installations are in accordance with the standard.

The Occupational Health and Safety Act, 1993 (Act No. 85 of 1993) (OHS Act), which is administered by the Chief Inspector of Occupational Health and Safety of the Department of Labour, requires that electrical installations comply with the requirements of SANS 10142-1. It also requires that a registered person, as defined (master installation electrician, installation electrician or electrical tester for single phase), will issue a Certificate of Compliance together with a test report. The certificate shall be in the form of the Certificate of Compliance published in the Electrical Installation Regulations, 2009, and the test report shall be in the form of the test report in this part of SANS 10142 (see 8.8).

Amdt 7

In terms of the OHS Act, the provisions of this part of SANS 10142 apply only from the point of control to the point of consumption.

Because this part of SANS 10142 is continually updated, problems can arise on which version of the standard will be applicable when a contract is signed. The date of approval of the latest revision or amendment of this part of SANS 10142 will be the implementation date of the revision or the amendment. The applicable version of this part of SANS 10142 is the one with the latest implementation date before the contract date. So contracts signed before the approval of an amendment have to be carried out in accordance with the provisions of the unamended standard. If an existing installation is extended or altered, such extension or alteration has to comply with the provisions of this part of SANS 10142 that were applicable at the time of the erection of the extension or alteration.

The edition of the standard that was applicable at the date of erection of an electrical installation is to be considered the edition defining the requirements applicable to that particular electrical installation.

SANS 10142-1:2012

Edition 1.8

(As amended 2003 and 2012)

Contents

	Page
Abstract.....	1
Keywords	1
Foreword	1
Introduction	3
1 Scope	19
1.1 Application of this part of SANS 10142	19
1.2 Aspects covered by this part of SANS 10142	20
1.3 Where this part of SANS 10142 is not applicable	20
1.4 Electrical equipment	21
2 Normative references	23
2.1 Compulsory standards	23
2.2 Standards.....	23
3 Definitions	33
4 Compliance	57
4.1 Compliance standards	57
4.2 Deleted by amendment No. 3.	
4.3 Applicable standards.....	58
4.4 Deleted by amendment No. 3.	
4.5 Notices, labels and rating plates	66
5 Fundamental requirements.....	69
5.1 Safety.....	69
5.1.1 Live parts	69
5.1.2 Temperature	69
5.1.3 Earth fault current protection.....	69
5.1.4 Positioning of equipment.....	71
5.1.5 Marking of equipment	71
	Amdt 8
5.2 Basic provisions.....	71
5.2.1 Estimated load	71
5.2.2 Voltage drop	71
5.2.3 Nominal cross-sectional area of conductors	72
5.2.4 Type of wiring and methods of installation	72
5.2.5 Protective equipment	72

SANS 10142-1:2012

Edition 1.8

(As amended Jan. 2003, Dec. 2003, 2008 and 2012)

Contents *(continued)*

	Page
Table 6.15	Correction factors for cables installed in enclosed trenches (installation methods 7, 8 and 9 (see table 6.1)) 131
Table 6.16	Correction factors for depth of cables buried in the ground..... 134
Table 6.17	Correction factors for neutral imbalance 135
Table 6.18	Correction factors for harmonic currents in multiphase circuits with neutral conductor 137
	Amdt 8
Table 6.19	Correction factors for direct solar radiation 138
Table 6.20	Current rating for concentric cables 139
Table 6.21	Aerial bundled conductors 140
Table 6.22	Capacity of conduit for single-core cables 153
Table 6.23	Values of <i>C</i> for conductor nominal cross-sectional area 154
Table 6.24	Values of <i>K</i> for conduit diameter..... 154
Table 6.25	Compliance of motor control components 163
	Amdt 3
Table 6.26	Maximum protection rating for nominal cross-sectional area of small conductors 165
	Amdt 1
Table 6.27	Deleted by amendment No. 1
Table 6.28	Minimum size and maximum length of copper earth continuity conductors 181
Table 6.29	Maximum mass of luminaire and supports 190
Table 7.1	Conditions under which electrical equipment may be installed in a bathroom..... 207
Table 7.2	Minimum cross-sectional area of earthing (PE) conductor for the corresponding phase conductor..... 239

SANS 10142-1:2003

Edition 1.1
(As amended 2003)

Contents (continued)

	Page
Table 7.3	The recommended length of a SELV circuit between the source and the load and the minimum size of SELV conductors for different lighting loads and voltages 250
	Amdt 3
Table 7.4	Minimum clearances in air for high-voltage apparatus..... 261
Table 7.5	Spacing of supports for high-voltage cables in HV signs 266
Table 8.1	Maximum resistance of earth continuity conductor 276
Table 8.2	Earth fault loop circuits for different distribution systems 277
Table E.1	Impedance of 600/1 000 V conductors that comply with SANS 1507307
Table E.2(a)	Maximum lengths, in metres, of copper cables/circuits at a given circuit-breaker current rating for single phase ($F_v = 2$)..... 309
Table E.2(b)	Maximum lengths, in metres, of copper cables/circuits at a given circuit-breaker current rating for three-phase ($F_v = 1$ balanced) 310
Table E.3	Multiplication factor F_v for the relevant circuit conditions..... 311
Table F.1	Minimum radius of curvature of cables 312
Table G.1	Calculation of C values for cables in conduit – example 1 314
Table G.2	Calculation of C values for cables in conduit – example 2 315
Table J.1	International protection ratings – IP ratings 323

SANS 10142-1:2012

Edition 1.8

(As amended 2003, 2008 and 2012)

Figure E.1	Example of voltage drop calculation for a cable installation with specific loads	304
Figure L.1.1	Installation mode of SPDs – Connection type 1 for TN-C-S supply systems	330
	Amdt 1; amdt 6	
Figure L.1.2	Installation mode of SPDs – Connection type 1 for TN-S supply systems	330
	Amdt 1; amdt 6	
Figure L.1.3	Installation mode of SPDs – Connection type 2	331
	Amdt 6	
Figure L.2.1	Risk to loss of human life 10^{-5} – Risk boundaries for different structures and service layouts	331(e)
	Amdt 6	
Figure M.2.1	TN-C-S system earthing	335
Figure M.2.2	TN-S system earthing	336
Figure M.2.3	TT system earthing	337
Figure M.2.4	IT system earthing	338
Figure M.2.5	TN-C system earthing	339
Figure N.1	Illustration of protective and functional earthing and equipotential bonding for information technology equipment	344
Figure S.1	Change-over switch connection where standby power feeds in at main supply	355
	Amdt 6	
Figure S.2	Change-over switch connection where a standby power generator feeds into a section of the main distribution board	356
	Amdt 6	
Figure S.3	Connection where UPS power feeds into a section of the main distribution board	357
	Amdt 6; amdt 8	
Figure S.4	Change-over switch connection where standby power feeds in after the main distribution board (point of supply) into a sub-distribution board	358
	Amdt 6	

SANS 10142-1:2009

Edition 1.7

(As amended 2009)

Certificates

8.8.1	Test report for all electrical installations.....	281
	Amdt 7	
8.8.2	Additional test report for a medical location.....	289
	Amdt 7	
8.8.3	Additional test report for a hazardous location.....	291
	Amdt 7	

Annex H Deleted by amendment No. 3.

2 Normative references

The following standards contain provisions which, through reference in this text, constitute provisions of this part of SANS 10142 only for the compliance of the products. Parties to agreements based on this part of SANS 10142 are encouraged to take steps to ensure the use of the most recent editions of the standards. Information on currently valid national and international standards can be obtained from the SABS Standards Division.

Amdt 4; amdt 5

2.1 Compulsory standards

Compulsory specification for circuit-breakers, as published by Government Notice No. R. 967 (Government Gazette 29265) of 6 October 2006. (VC 8036)

Compulsory specification for earth leakage protection units, as published by Government Notice No. 2286 (Government Gazette 10987) of 16 October 1987. (VC 8035)

Compulsory specification for manually operated switches for fixed installations, as published by Government Notice No. R. 438 (Government Gazette 18779) of 3 April 1998. (VC 8003)

Compulsory specification for plugs, socket-outlets and socket-outlet adaptors, as published by Government Notice No. R. 1075 (Government Gazette 33763) of 19 November 2010. (VC 8008)

Compulsory specification for the safety of electric cables with extruded solid dielectric insulation for fixed installations (300/500 V to 1 900/3 300 V), as published by Government Notice No. R. 1165 (Government Gazette 25306) of 15 August 2003. (VC 8075)

Compulsory specification for safety of flexible cords for electrical appliances, as published by Government Notice No. R. 1079 (Government Gazette 33763) of 19 November 2010. (VC 8006)

2.2 Standards

2.2.1 South African standards

SANS 152 (SABS 152), *Low-voltage air-break switches, air-break disconnectors, air-break switch-disconnectors, and fuse-combination units*. (Superseded by SANS 60947-3.)

Amdt 4

SANS 10142-1:2008

Edition 1.6

(As amended 2005, 2006 and 2008)

SANS 156, *Moulded-case circuit-breakers.*

SANS 164-0, *Plug and socket-outlet systems for household and similar purposes for use in South Africa – Part 0: General and safety requirements.* **Amdt 5**

SANS 164-1, *Plug and socket-outlet systems for household and similar purposes for use in South Africa – Part 1: Conventional system, 16 A 250 V a.c.* **Amdt 5**

SANS 164-2, *Plug and socket-outlet systems for household and similar purposes for use in South Africa – Part 2: IEC system, 16 A 250 V a.c.* **Amdt 5**

SANS 164-3, *Plug and socket-outlet systems for household and similar purposes for use in South Africa – Part 3: Conventional system, 6 A 250 V a.c.* **Amdt 5**

SANS 164-4, *Plug and socket-outlet systems for household and similar purposes for use in South Africa – Part 4: Dedicated system, 16 A 250 V a.c.* **Amdt 5**

SANS 164-5, *Plug and socket-outlet systems for household and similar purposes for use in South Africa – Part 5: Two-pole, non-rewirable plugs, 2,5 A 250 V a.c., with cord, for connection of class II equipment.* **Amdt 5**

SANS 164-6, *Plug and socket-outlet systems for household and similar purposes for use in South Africa – Part 6: Two-pole systems, 16 A 250 V a.c., for connection of class II equipment.* **Amdt 6**

SANS 337, *Stove couplers.* **Amdt 5**

SANS 529, *Heat-resisting wiring cables.*

SANS 556-1, *Low-voltage switchgear – Part 1: Circuit-breakers.* **Amdt 4**

SANS 767-1, *Earth leakage protection units – Part 1: Fixed earth leakage protection circuit-breakers.*

SANS 780, *Distribution transformers.*

SANS 10142-1:2012

Edition 1.8

(As amended 2005, 2008 and 2012)

SANS 61386-21/IEC 61386-21, *Conduit systems for cable management – Part 21: Particular requirements – Rigid conduit systems.* **Amdt 4**

SANS 61386-22/IEC 61386-22, *Conduit systems for cable management – Part 22: Particular requirements – Pliable conduit systems.* **Amdt 4**

SANS 61386-23/IEC 61386-23, *Conduit systems for cable management – Part 23: Particular requirements – Flexible conduit systems.* **Amdt 4**

SANS 61558-1/IEC 61558-1, *Safety of power transformers, power supplies, reactors and similar products – Part 1: General requirements and tests.*

SANS 61558-2-2/IEC 61558-2-2, *Safety of power transformers, power supplies, reactors and similar products – Part 2-2: Particular requirements and tests for control transformers and power supplies incorporating control transformers.* **Amdt 4**

SANS 61558-2-5/IEC 61558-2-5, *Safety of transformers, reactors, power supply units and combinations thereof – Part 2-5: Particular requirements and test for transformers for shaver power supply units for shavers and shaver supply units.*

SANS 61558-2-6/IEC 61558-2-6, *Safety of transformers, reactors, power supply units and similar products for supply voltages up to 1 100 V – Part 2-6: Particular requirements and tests for safety isolating transformers and power supply units incorporating safety isolating transformers.*

SANS 61558-2-15/IEC 61558-2-15, *Safety of power transformers, power supply units and similar – Part 2-15: Particular requirements for isolating transformers for the supply of medical locations.*

SANS 61643-1/IEC 61643-1, *Low-voltage surge protective devices – Part 1: Surge protective devices connected to low-voltage power distribution systems – Requirements and tests.*

SANS 61643-12/IEC 61643-12, *Low-voltage surge protective devices – Part 12: Surge protective devices connected to low-voltage power distribution systems – Selection and application principles.* **Amdt 6**

SANS 62040-1/IEC 62040-1, *Uninterruptible power systems (UPS) – Part 1: General and safety requirements for UPS.* **Amdt 8**

SANS 10142-1:2012

Edition 1.8

(As amended 2003, 2006, 2008 and 2012)

SANS 62053-11/IEC 62053-11, *Electricity metering equipment (a.c.) – Particular requirements – Part 11: Electromechanical meters for active energy (classes 0,5, 1 and 2).* **Amdt 4**

SANS 62053-21/IEC 62053-21, *Electricity metering equipment (a.c.) – Particular requirements – Part 21: Static meters for active energy (classes 1 and 2).* **Amdt 4**

SANS 62103/IEC 62103, *Electronic equipment for use in power installations.* **Amdt 8**

SANS 62305-1/IEC 62305-1, *Protection against lightning – Part 1: General principles.* **Amdt 6**

SANS 62305-2/IEC 62305-2, *Protection against lightning – Part 2: Risk management.* **Amdt 6**

SANS 62305-3/IEC 62305-3, *Protection against lightning – Part 3: Physical damage to structures and life hazard.* **Amdt 6**

SANS 62305-4/IEC 62305-4, *Protection against lightning – Part 4: Electrical and electronic systems within structures.* **Amdt 6**

2.2.2 International and foreign standards

BS 1363-2, *13 A plugs, socket-outlets, adaptors and connection units – Specification for 13 A switched and unswitched socket-outlets.* **Amdt 5**

IEC 60664-1, *Insulation coordination for equipment within low-voltage systems – Part 1: Principles, requirements and tests.*

IEC 60695-2-10, *Fire hazard testing – Part 2-10: Glowing/hot-wire based test methods – Glow-wire apparatus and common test procedure.*

IEC 61557-8, *Electrical safety in low voltage distribution systems up to 1 000 V a.c. and 1 500 V d.c. – Equipment for testing, measuring or monitoring of protective measures – Part 8: Insulation monitoring devices for IT systems.*

IEC/TR 62066, *Surge overvoltages and surge protection in low-voltage a.c. power systems – General basic information.* **Amdt 6**

UL 508, *Industrial control equipment.*

SANS 10142-1:2012

Edition 1.8

(As amended Jan. 2003, Dec. 2003 and 2012)

NOTE 1 Table 4.2 lists the standards applicable in this part of SANS 10142.

Amdt 3; amdt 8

NOTE 2 When a standard has been amended or replaced, the superseded standard will remain in force

Amdt 8

- a) for a period of one year from the date of publication of the amended or substitution standard, or **Amdt 8**
- b) as determined in the amended or substitution standard, or **Amdt 8**
- c) as provided for in a compulsory standard. **Amdt 8**

3 Definitions

For the purposes of this part of SANS 10142, the following definitions apply:

3.1

acceptable

acceptable to the Regulator

Amdt 1

3.2

accessible

not permanently closed in by the structure or surface(s) of the premises

3.3 Deleted by amendment No. 3.

3.3.1 Deleted by amendment No. 3.

3.3.2 Deleted by amendment No. 3.

SANS 10142-1:2003

Edition 1.1

(As amended 2003)

3.3.3 Deleted by amendment No. 3.

3.3.4 Deleted by amendment No. 3.

3.4

appliance

machine, tool, device or instrument that is operated by electricity for the purpose of doing work, or for providing heat, light or motion, or in which electrical energy is modified into another form of energy

3.4.1

class I appliance

appliance that has at least basic insulation throughout, and that is provided with an earthing terminal or earthing contact and is designed (in the case of single phase) for connection by means of a three-core flexible cord

3.4.2

class II appliance

appliance that has double insulation or reinforced insulation (or both) throughout, and that is without provision for earthing

3.4.3

fixed appliance

appliance that is fastened or otherwise secured at a specific location, and that would require the use of tools to be moved to another location

3.4.4

portable appliance

appliance that is moved in the course of normal operation

3.4.5

stationary appliance

appliance that is normally not moved or cannot easily be moved while in operation

Table 4.2 (continued)

1	2	3	4
Commodity	Scope	Safety standard ^b	Recommended performance standard ^b
Conduit	Conduit and fittings: rigid pliable flexible PVC rigid conduit and fittings: 20 mm to 63 mm dia. Metal conduit: 20 mm to 50 mm dia. Metal fittings		SANS 61386-1 SANS 61386-21 SANS 61386-22 SANS 61386-23 SANS 950 SANS 1065-1 ^d SANS 1065-2 ^d
Connectors (terminals)	Terminal blocks: <ul style="list-style-type: none"> – clamping: $\leq 300 \text{ mm}^2$ – screw type: $\leq 35 \text{ mm}^2$ Flat push-on: <ul style="list-style-type: none"> – $0,75 \text{ mm}^2$ to 10 mm^2 – $\leq 300 \text{ }^\circ\text{C}$ 		SANS 1433-1 IEC 60998-2-1 IEC 60998-2-2 SANS 1433-2
Contactors, motor starters and overload relays	All	SANS 60947-4-1 SANS 60947-4-2 SANS 60947-4-3 UL 508	
Disconnectors (non-trip)	$\leq 1\ 000 \text{ V a.c.}$ or $1\ 500 \text{ V d.c.}$	SANS 60947-3	

Amdt 1; amdt 3; amdt 4; amdt 5

61(b)

Table 4.2 (continued)

1	2	3	4
Commodity	Scope	Safety standard ^b	Recommended performance standard ^b
Distribution boards	≤ 10 kA short-circuit current low-voltage switchgear and controlgear Assemblies > 10 kA For outdoor use and exposed to public Assemblies for construction sites	SANS 1765 SANS 1973-3 SANS 1473-1 SANS 1973-1 SANS 1973-8 SANS 60439-5 SANS 60439-4	
Earth leakage circuit-breakers (ELCBs)	$I_{\Delta n} \leq 30$ mA ≤ 500 V and ≤ 100 A See NOTE	VC 8035	
Earth leakage circuit-breakers (ELCBs)	$I_n \leq 125$ A; $I_{\Delta n} > 30$ mA ≤ 500 V and ≤ 100 A See NOTE	SANS 60947-2	
Earth leakage circuit-breakers (ELCBs)	$I_n > 125$ A; $I_{\Delta n} > 30$ mA $\leq 1\ 000$ V See NOTE	SANS 60947-2	
Earth leakage switches (ELSWs)	$I_{\Delta n} \leq 30$ mA ≤ 500 V and ≤ 100 A See NOTE	VC 8035	
Earth leakage switches (ELSWs)	$I_{\Delta n} > 30$ mA ≤ 440 V and ≤ 125 A See NOTE	SANS 61008-1 (ed. 2.2)	

Amdt 3; amdt 6; amdt 8

Table 4.2 (continued)

1	2	3	4
Commodity	Scope	Safety standard ^b	Recommended performance standard ^b
Earth leakage circuit-breakers (ELCBs) used as switch-disconnectors (with isolation function)	$I_{\Delta n} \leq 30 \text{ mA}$ $\leq 500 \text{ V}$ and $\leq 100 \text{ A}$ See NOTE	VC 8035 plus 7.2.7 of SANS 556-1	
Earth leakage circuit-breakers (ELCBs) used as switch-disconnectors (with isolation function)	$I_{\Delta n} \leq 125 \text{ A}$; $I_{\Delta n} > 30 \text{ mA}$ $\leq 500 \text{ V}$ and $\leq 100 \text{ A}$ See NOTE	SANS 60947-2 and classified with isolation function	
Earth leakage circuit-breakers (ELCBs) used as switch-disconnectors (with isolation function)	$I_{\Delta n} > 125 \text{ A}$; $I_{\Delta n} > 30 \text{ mA}$ $\leq 1\ 000 \text{ V}$ See NOTE	SANS 60947-2 and classified with isolation function	
Earth leakage switches (ELSWs) used as switch-disconnectors (with isolation function)	$I_{\Delta n} \leq 30 \text{ mA}$ $\leq 500 \text{ V}$ and $\leq 100 \text{ A}$ See NOTE	VC 8035 plus 7.2.7 of SANS 556-1	
Earth leakage switches (ELSWs) used as switch-disconnectors (with isolation function)	$I_{\Delta n} > 30 \text{ mA}$ $\leq 440 \text{ V}$ and $\leq 125 \text{ A}$ See NOTE	SANS 61008-1 (ed. 2.2)	
Earth rods	All		SANS 1063
Earth wire	Bare copper	SANS 1411-1	
Electrical and electronic equipment for use in installations ("black box")	All		SANS 62103
Electricity dispensers (pre-payment meters)	All		SANS 1524-1
Emergency stop devices	With mechanical latching function	SANS 60947-5-5	
Enclosures	IP ratings		SANS 60529

Amdt 3; amdt 6; amdt 8

62(a)

SANS 10142-1:2012
 Edition 1:8
 (As amended 2003, 2008 and 2012)

SANS 10142-1:2012
Edition 1.8
(As amended 2003, 2008 and 2012)

62(b)

Table 4.2 (continued)

1	2	3	4
Commodity	Scope	Safety standard ^b	Recommended performance standard ^b
Ferrules and lugs	Ferrules and lugs for copper and aluminium conductors		SANS 61238-1
Fuses (low-voltage)	Rated voltage < 1 000 V a.c. Breaking capacity at least 6 kA Rated current < 1 250 A Rated voltage < 690 V a.c.	SANS 60269-1	
Light dimmers ^f	For incandescent lamps – – electromechanical 250 V – electronic – maximum of 3 kW	SANS 1012 SANS 60669-2-1	
Luminaires	ELV systems Pools and similar applications Supply track systems	SANS 60598-2-23 SANS 60598-2-18 SANS 60570	
Medical electrical equipment	General		SANS 60601-1
Medical monitoring devices	Medical IT systems	IEC 61557-8	
Meter cabinets	For outdoor use and exposed to public	SANS 60439-5	
Outlet boxes	All		SANS 1085
Proximity switches	Not with analogue outputs < 250 V		SANS 60947-5-2
Push buttons, indicator lights, etc.	Electromechanical control circuit devices – ≤ 1 000 V	SANS 60947-5-1	
Ready boards (SPDU)	Non-extendable and extendable – rated 230 V	SANS 1619	
Shaver supply transformers (isolating transformers)	Input: 250 V a.c. supply Output: 110/230 V a.c. Isolating; 20 VA to 50 VA	SANS 61558-2-5	

Amdt 3; amdt 5; amdt 8

Table 4.2 (continued)

1	2	3	4
Commodity	Scope	Safety standard ^b	Recommended performance standard ^b
Socket-outlets ^g	6 A, 3-pin, 250 V 16 A, 3-pin, 250 V Dedicated 16 A, 3-pin, 250 V IEC systems for SELV plugs and socket-outlets 13 A fused flat pin	VC 8008 and SANS 164-3 VC 8008 and one of SANS 164-1 or SANS 164-2 VC 8008 and SANS 164-4 SANS 60906-3 BS 1363-2	
Socket-outlets (industrial type)	≤ 690 V; ≤ 250 A	SANS 1239 SANS 60309-1 and SANS 60309-2	
Stove coupler	All	SANS 60309-1 of dimensions as in SANS 337	
Surge arresters for low-voltage systems	≤ 1 000 V	SANS 61643-1	
Switches (manually operated)	50 V – 440 V; 63 A	VC 8003 ^a	
Switches (photoelectric)	≤ 1 800 VA; 230 V		SANS 1777
Switches and switch-disconnectors (non-trip)	≤ 1 000 V a.c. or 1 500 V d.c.	SANS 60947-3	
Switch-disconnectors (trip)			See circuit-breakers used as switch-disconnectors
Timer switches	All		IEC 60730-2-7
Transfer switches	< 1 000 V	SANS 60947-6-1	
Transformers (distribution)	≤ 3 150 kVA Maximum 36 kV	SANS 780	

Amdt 3; amdt 4; amdt 5; amdt 6; amdt 8

Table 4.2 (concluded)

1	2	3	4
Commodity	Scope	Safety standard ^b	Recommended performance standard ^c
Transformers (isolating)	Test Control Separating (double-wound) Shaver units Safety isolating Medical locations Electronic convertors (for lamps)	SANS 61558-1 SANS 61558-2-2 SANS 61558-2-4 SANS 61558-2-5 SANS 61558-2-6 SANS 61558-2-15 SANS 61347-2-2	
Uninterruptible power systems	All		SANS 62040-1
Watt-hour meters	Electromechanical induction type < 600 V Electronic static for active energy < 600 V		SANS 1607 ^d SANS 1799 SANS 62053-11 SANS 61036 ^d SANS 62053-21
Wireways	Busways/busbar trunking Cable trunking and ducting for electrical installations		SANS 60439-2 SANS 61084-1
NOTE Only non-auto-reclosing and double-pole earth leakage protection devices may be used according to 6.7.5.1 and 6.7.5.3(b).			
<p>^a See 2.1</p> <p>^b For equivalent SABS numbers to SANS standards, see clause 2.</p> <p>^c Included for a limited period to ensure a smooth transition to SANS 556-1.</p> <p>^d Superseded.</p> <p>^e To be withdrawn in 2009.</p> <p>^f Light dimmers and switches that form part of the lighting circuit for incandescent lamps shall comply with one of the safety standards in column 3, as applicable.</p> <p>^g As from January 2011, in terms of the compulsory specification for plugs, socket-outlets and socket-outlet adaptors (VC 8008), BS 1363-2 socket-outlets may no longer be sold in South Africa.</p>			

Amdt 1; amdt 3; amdt 4; amdt 6, amdt 8

SANS 10142-1:2003

Edition 1.1

(As amended 2003)

4.4 Deleted by amendment No. 3.

4.5 Notices, labels and rating plates

Any notices, labels or rating plates that are required in terms of this part of SANS 10142 shall be durable and not removable except by determined and deliberate action. The inscriptions shall be legible and indelible. Details on the topics given in column 2 of table 4.3 can be found in the relevant subclauses in column 1.

Table 4.3 – Notices, labels and rating plates

1	2
Subclause	Topic
5.2.8(f)	Position of concealed distribution board
6.6.1.1	Switch-disconnectors for distribution boards and sub-distribution boards
6.6.1.13	Identification of ring circuits
6.6.1.20	Identification of incoming and outgoing circuits of distribution boards
6.6.1.21	Warning labels on distribution boards
6.6.1.21(e)	Position of readily accessible earthing terminal for other services
6.6.6.2(e)	Alterations or changes to a distribution board
6.7.4(d)	Series-connected (cascaded) systems
6.7.5.6	Standard socket-outlets not on 30 mA earth leakage or with a rated tripping current higher than 30 mA.
6.7.5.6	Socket-outlets powered from a safety supply or on dimmer control
6.8.2.2	Circuit controlled by circuit-breaker
6.8.2.3(b)	Load and line markings on circuit-breakers used as switches
6.9.1.1	Main switch-disconnectors in the case of multisupplies
6.9.3.2	Disconnecting devices with remote control
6.9.3.3, NOTE 2	Disconnecting devices other than switch-disconnectors
6.10.4	Maximum permissible current rating of fuse-protected circuits
6.11.5	Earthing terminal for other services
6.14.1.7(a)	More than one phase or circuit in an enclosure
6.14.1.8	More than one circuit brought into an enclosure
6.15.1.3(a)	Voltage rating on socket-outlets if not standard voltage
6.15.3(c)(5)	Maximum rating of back-up short-circuit protective device
6.15.7.2	Socket-outlets on ring circuits
6.16.1.3	Position of disconnecting device for remotely installed appliance

Amdt 5; amdt 8

SANS 10142-1:2012

Edition 1.8

(As amended 2009 and 2012)

1	2
Subclause	Topic
7.4.2	Supply from which equipment is supplied
7.6.3.1	Socket-outlets in caravan parks, mobile homes and marina sites
7.8.3.1	Each distribution circuit that supplies a temporary structure
7.9.4.5	Identification of a protective device not immediately evident
7.10.1.6(b)	Socket-outlets supplied by a dimmer
7.11.5	Manual control of the emergency lighting supply
7.12.2.1	Main switch where an alternative supply is installed
7.13.1	High-voltage equipment
7.13.3.2	High-voltage signs
7.13.7.1(a)	Enclosure of a step-up transformer for HV apparatus
7.13.10.5(g), (h)	Fireman's switch
7.13.11.2(b)	Terminations of conductors for HV circuits

Amdt 5; amdt 8

SANS 10142-1:2012

Edition 1.8

(As amended 2006 and 2012)

5 Fundamental requirements

All commodities in an electrical installation shall be installed in accordance with the requirements in this part of SANS 10142 and with the manufacturer's instructions, where applicable. **Amdt 8**

NOTE 1 This clause contains the general safety principles applicable to electrical installations. **Amdt 5; amdt 8**

NOTE 2 The manufacturer's instructions may contain more stringent requirements. **Amdt 8**

5.1 Safety

5.1.1 Live parts

It shall not be possible to touch any live part within arm's reach with the standard test finger (see SANS 60529) **Amdt 5**

- a) during normal operation, or
- b) when a cover is removed, unless the cover is removed with the use of a tool or a key.

5.1.2 Temperature

5.1.2.1 Unless otherwise permitted by an applicable standard (see 4.3 and table 4.2), electrical equipment shall be so designed, positioned and protected that accessible parts under normal operating conditions do not reach a temperature (safe touch temperature) that exceeds

- a) 70 °C in the case of metallic parts, and
- b) 90 °C in the case of non-metallic parts.

5.1.2.2 If electrical equipment has to be mounted in a fire risk area or adjacent to flammable material, the equipment shall be

- a) of, or enclosed by, thermally non-conductive non-flammable material, or
- b) so designed or positioned (or both) that the flammable material is not subjected to any hazardous heating, or
- c) so designed or positioned (or both) that any arc or sparks are contained within the enclosure.

SANS 10142-1:2012

Edition 1.8

(As amended 2009 and 2012)

5.1.3 Earth fault current protection

5.1.3.1 A new electrical installation shall not be connected to the supply unless the supply includes a protective conductor. (See also 6.11 and 8.7.3.)

5.1.3.2 People, animals and property shall be protected against harmful earth fault currents by protective measures such as

- a) earthing and bonding,
- b) electrical separation of circuits,

NOTE The expression "electrical separation of a circuit" means that the circuit is electrically isolated from other circuits in an installation. If an electrically separate circuit is short and is well protected against damage (for example, as in a shaver unit), it is unlikely that there will be faults on the circuit. However, if the circuit is long, the risk of one conductor faulting to earth increases. One fault will reduce the effectiveness of "electrical separation of a circuit" as a protective measure; a second fault can be dangerous. To be able to rely on "electrical separation of a circuit" as a protective measure for a long circuit, a specially designed device should be used to monitor the circuit, and, if a fault occurs, the device should disconnect the circuit or give an audible or a visible warning of the fault.

- c) the use of an isolating transformer with an output of 50 V or less,
- d) the use of electrical equipment that is double insulated, or

NOTE Electrical equipment that complies with an applicable standard (see 4.3 and table 4.2) and that bears the symbol  is deemed to be double insulated.

- e) the use of earth leakage protection for socket-outlet circuits. **Amdt 8**

5.1.3.2.2 The rated earth leakage tripping current (rated residual current) $I_{\Delta n}$ required to activate an earth leakage protection device shall not exceed 30 mA.

Amdt 8

5.1.3.3 Earth leakage protection shall not be used as an alternative protective measure to those given in 5.1.3.2(a) and 5.1.3.2(b). Earth leakage protection shall be considered an additional protective measure. (See also 6.7.5.)

5.1.3.4 The protective measures described in 5.1.3.2(a) to 5.1.3.2(d) may be applied to a

- a) complete installation,
- b) part of an installation,
- c) circuit, or
- d) locality.

No protective measure shall interfere with the operation of any other protective measure

5.1.4 Positioning of equipment

Electrical equipment which, under normal conditions will be

- a) exposed to flammable or explosive gas, vapour, dust or liquid, or to external influences such as direct sunlight, corrosive vapour or oil, or
- b) in a hazardous location,

shall be so selected or enclosed that it is protected against harmful effects or it shall comply with the requirements of an applicable standard (or both).

5.1.5 Marking of equipment

Amdt 8

All equipment and circuits shall be labelled as required by this part of SANS 10142. (See also 4.5.)

Amdt 8

5.2 Basic provisions

5.2.1 Estimated load

A registered person or an electrical consultant shall estimate the load of an installation to determine the type and capacity of the required electricity supply.

Amdt 8

NOTE 1 Annex D gives an example of estimating the load for residential installations but the method is not to be regarded as an exact method.

NOTE 2 The supplier may have special requirements for large installations and for installations that need special consideration.

SANS 10142-1:2012

Edition 1.8

5.2.2 Voltage drop

5.2.2.1 When all conductors of an a.c. installation are carrying their maximum estimated load, the difference in voltage (the voltage drop) between the point of supply and any point of outlet or terminals of fixed appliances shall not exceed 5 % of the standard voltage or of the declared phase-to-neutral voltage (see also 6.2.7). In the case where reticulation is part of the electrical installation after the point of supply, the 5 % voltage drop shall be calculated to include the reticulation part of the installation (for example, in the case of a housing scheme where further submetering with a further point of control is installed for individual consumers).

5.2.2.2 When all conductors of a d.c. installation are carrying their maximum estimated load, the difference in voltage (the voltage drop) between any point of supply and any point of consumption shall not exceed 5 % of the circuit nominal voltage or as determined by the specific equipment requirements. **Amdt 4**

SANS 10142-1:2009

Edition 1.7

(As amended 2009)

5.2.3 Nominal cross-sectional area of conductors

The nominal cross-sectional area of a conductor shall be determined in accordance with the following safety considerations:

- a) the conductor's maximum permissible continuous temperature;
- b) the permissible voltage drop of an installation;
- c) the electromechanical stresses and thermal effects that are likely to occur as a result of short-circuits;
- d) the maximum impedance of the conductor with respect to the functioning of the short-circuit protection; and
- e) mechanical stresses.

NOTE Nominal cross-sectional areas exceeding those necessary for safety may be required for practical operation.

5.2.4 Type of wiring and methods of installation

The type of wiring and methods of installation shall be determined after consideration of the following:

- a) the location (also consider intentional or inadvertent damage);
- b) the nature of the building elements for supporting the wiring;
- c) the accessibility of the wiring to persons and livestock;
- d) the voltage;
- e) the electromechanical stresses and thermal effects likely to occur as a result of short-circuits; and
- f) stresses imposed on the wiring during installation and in service.

5.2.5 Protective equipment

Protective devices shall operate at currents and voltages and within periods of time that are related to the characteristics of the circuit that they serve. The type of protective device needed shall be determined in accordance with its function, which can be to protect the circuit against the following:

SANS 10142-1:2008

Edition 1.6

(As amended 2008)

6.2.3.4 The tabulated current-carrying capacity (given in tables 6.2(a) to 6.9(a)) relates to a single circuit in the installation methods (shown in table 6.1), in an ambient air temperature of 30 °C. The current-carrying capacity (given in the said tables) for a.c. operation applies only to frequencies in the range 49 Hz to 61 Hz.

6.2.3.5 In extreme cases, notably for large multicore cables, the reduction in current-carrying capacity of the cables (for example, balanced 400 Hz a.c. compared with the current-carrying capacity at 50 Hz), may be as much as 50 %.

6.2.3.6 For small cables and flexible cords, such as may be used to supply individual tools, the difference between 50 Hz and the 400 Hz current-carrying capacities may be negligible.

6.2.4 Methods of cable installation

Table 6.1 lists the descriptions and the numbers of installation methods to be used for the determination of the current-carrying capacities of conductors in the selection of the appropriate cable size. The use of other methods is not precluded where a suitably qualified person has specified it.

For other conditions, appropriate correction factors shall be applied as described in 6.2.5.

6.2.5 Application of tables and correction factors for current-carrying capacity

6.2.5.1 To determine the current-carrying capacity of a cable for a particular method of installation, multiply the value of current-carrying capacity obtained from tables 6.2(a) to 6.9(a) by the correction factors for each of the following, where applicable:

Amdt 6

- a) ambient temperature (see table 6.10);
- b) grouping and number of cables on racks or trays (see table 6.14);
- c) grouping and number of cables in a trench (see table 6.15);
- d) grouping and number of cables buried directly in the ground (see tables 6.11, 6.12, 6.13 and 6.16);

SANS 10142-1:2012

Edition 1.8

(As amended 2008 and 2012)

- e) neutral imbalance (see table 6.17);
- f) harmonics (see table 6.18); and
- g) direct solar radiation (see table 6.19).
- h) Deleted by amendment No. 6.

6.2.5.2 Once the current-carrying capacity has been determined, after all correction factors had been considered, carry out the load power factor and voltage drop calculations to determine whether the voltage drop will be within the allowed 5 %.

Amdt 6

6.2.6 Effective current-carrying capacity

6.2.6.1 The current-carrying capacity of a cable corresponds to the maximum current that can be carried in specified conditions without the conductors exceeding the permissible limit of steady state temperature for the type of insulation concerned.

6.2.6.2 The value of a tabulated current represents the effective current-carrying capacity only where no correction factor is applicable. Otherwise the current-carrying capacity of a cable corresponds to the tabulated value multiplied by the appropriate correction factor or factors for ambient temperature, grouping, neutral imbalance, harmonics, thermal insulation and solar radiation, as applicable.

6.2.6.3 Irrespective of the type of overcurrent protective device associated with the conductors concerned, the ambient temperature correction factors to be used when calculating current-carrying capacity (as opposed to those used when selecting cable sizes) are given in table 6.10.

6.2.6.4 For the size and construction of a cable and for the conditions of use, other than those covered in this clause and the following tables, the current-carrying capacity shall be taken as that specified by the manufacturer or as given in SANS 10198-4.

6.2.6.5 Conditions of installation for cables buried in the ground are given in tables 6.8, 6.11, 6.12, 6.13 and 6.16. For cables not covered, see SANS 10198-4.

6.2.6.6 Where CFL (compact fluorescent lamp) lighting is installed, the rating of the conductors shall be based on double the sum of the lamp load, in watts (see also 6.2.11.2.3 and 6.14).

Amdt 8

Table 6.17 — Correction factors for neutral imbalance

1	2
Neutral current as percentage of phase current %	Correction factors
0	1,00
25	0,97
50	0,94
75	0,90

6.2.10.2 Irrespective of 6.2.10.1, the current-carrying capacity of a neutral conductor shall

- a) in a single-phase circuit, be at least equal to that of the phase conductor,
- b) in a multiphase circuit (when single-pole protective devices are used), be at least equal to that of the phase conductor;
- c) in a multiphase circuit that uses a multipole protective device, be such that the neutral conductor can carry the maximum predictable out-of-balance current under normal operating conditions, and
- d) in a three-phase circuit that supplies discharge lighting, the nominal cross-sectional area of the neutral shall be at least equal to the nominal cross-sectional area of the associated phase conductor.

6.2.11 Correction factors for harmonic currents

6.2.11.1 Effects of harmonic currents on balanced three-phase systems

6.2.11.1.1 In the situation where current flows in the neutral of a balanced three-phase system, such neutral currents are due to the line current having a harmonic content that does not cancel in the neutral. The most significant harmonic which does not cancel in the neutral is usually the third harmonic. The magnitude of the neutral current due to the third harmonic may exceed the magnitude of power frequency phase current. The neutral current will then have a significant effect on the current-carrying capacity of cables in the circuit.

SANS 10142-1:2012

Edition 1.8

(As amended 2008 and 2012)

6.2.11.1.2 The correction factors apply to balanced three-phase circuits; it is recognized that the situation is more onerous if only two of the three phases are loaded. In this situation the neutral conductor will carry the harmonic currents in addition to the unbalanced current; such a situation can lead to overloading of the neutral conductor.

6.2.11.1.3 Equipment likely to cause significant harmonic currents is, for example, fluorescent lighting banks and d.c. power supplies such as those found in computers.

6.2.11.1.4 The tabulated correction factors, when applied to the current-carrying capacity of the cable with three loaded conductors, will give the current-carrying capacity of a cable with four loaded conductors where the current in the fourth conductor is due to harmonics. The correction factors also take the heating effect of the harmonic current in the phase conductors into account.

6.2.11.1.5 Further information on harmonic disturbances can be found in IEC 61000-4-7.

6.2.11.2 Harmonic currents in four-core and five-core cables with four cores that carry current

6.2.11.2.1 Where the neutral conductor carries current without a corresponding reduction in the load of the phase conductor, the current that flows in the neutral conductor shall be taken into account in ascertaining the current-carrying capacity of the circuit.

6.2.11.2.2 The correction factors given in table 6.18 only apply to cables where the neutral conductor is in a multicore cable and is of the same material and cross-sectional area as the phase conductor. The correction factors calculated were based on third harmonic currents. If more than 10 % of higher harmonics (9th, 12th, etc.), are experienced, the lower correction factors are applicable. Where there is an unbalance between phases of more than 50 %, the lower correction factors may be applicable. **Amdt 8**

6.2.11.2.3 Where the neutral current is expected to be higher than the phase current, the cable size shall be selected based on the neutral current (see 6.2.6.6). **Amdt 8**

6.2.11.2.4 Where the cable size selection is based on a neutral current, which is not significantly higher than the phase current, it is necessary to reduce the tabulated current-carrying capacity for the three loaded conductors. **Amdt 6**

6.2.11.2.5 If the neutral current is more than 135 % of the phase current and the cable size is selected based on the neutral current, the three phase conductors will not be fully loaded. The reduction in heat generated by the phase conductors offsets the heat generated by the neutral conductor to the extent that it is not necessary to apply any correction factor to the current-carrying capacity for three loaded conductors.

Table 6.18 — Correction factors for harmonic currents in multiphase circuits with neutral conductor

Amdt 8		
1	2	3
Third harmonic content of phase current %	Correction factors	
	Size selection is based on phase current	Size selection is based on zero sequence current in the neutral
0 – 15	1,0	–
15 – 33	0,86	–
33 – 45	–	0,86
> 45	–	1,0
Where CFL lighting is installed, the rating of the conductors shall be based on double the sum of the lamp load, in watts. Amdt 8		
NOTE 1 Where harmonic current is present, the cable size is selected on the basis of the zero sequence current in the neutral. Amdt 8		
NOTE 2 See 6.2.11.2.4 and 6.2.11.2.5 for the rating of the neutral conductor in relation to the phase conductors in a three-phase circuit. Amdt 8		

Amdt 6

SANS 10142-1:2003

Edition 1.1

6.2.12 Correction factors for direct solar radiation

Select the appropriate correction factor from table 6.19.

Table 6.19 — Correction factors for direct solar radiation

1	2	3
Cross-sectional area of conductor mm ²	Correction factors	
	Solar radiation	
	1 000 W/m ² (coastal)	1 250 W/m ² (highveld)
1,5 – 10	0,70	0,62
16 – 35	0,68	0,57
50 – 95	0,65	0,53
120 – 185	0,62	0,49
240 – 400	0,59	0,44
NOTE For concentric (airdac) cables, see 6.2.13 (table 6.20).		

6.2.13 Single-phase concentric cables for aerial service connections

6.2.13.1 Concentric and split concentric cables are single-phase XLPE insulated copper cables available in sizes 4 mm², 10 mm² and 16 mm² and are designed for aerial application, but may also be used underground. These cables are primarily used for the provision of an electricity supply from a distribution main or aerial bundled conductor (ABC) system to individual houses. For current ratings, see table 6.20.

6.2.13.2 Split concentric cables are provided with an integral earthing conductor and can be used in single-phase circuits in an electrical installation.

6.2.13.3 Concentric cables only contain a phase and concentric conductor to be used in combined neutral earth systems which does not make it suitable for circuits in an electrical installation except where a separate earthing conductor is installed.

SANS 10142-1:2003

Edition 1.1

(As amended 2003)

- 3) the colours may be applied at the ends of a conductor by means of durable colour marking (e.g. insulating sleeves or by electrical insulating tape wound more than once around the conductor).

Amdt 1

- c) Where symbols are used
 - 1) the polarity of the positive conductor shall be identified by the + symbol,
 - 2) the polarity of the negative conductor shall be identified by the - symbol, and
 - 3) the symbols shall be applied at the ends of the conductor. The symbols may be applied by means of printed adhesive tape or cable markers.
- d) In an earthed d.c. installation, either the positive or the negative conductor may be earthed. The earthing system used in the installation shall be indicated by means of a notice placed at the d.c. supply.
- e) Where an installation contains both a.c. and d.c. circuits and colour is used to identify the polarity of the d.c. conductors, polarity symbols described in (c) above shall be added at both ends of the d.c. conductors to distinguish them from the a.c. conductors.

6.3.4 Aerial conductors

6.3.4.1 An aerial conductor shall be of

- a) hard-drawn copper,
- b) stranded aluminium, or
- c) composite construction, such as steel-cored aluminium.

6.3.4.2 A surge arrester should be installed at each end of each aerial conductor circuit in an installation (see 6.7.6).

Amdt 1

NOTE The arrangement, support and, where required, insulation of an aerial conductor has to comply with the relevant statutory requirements.

SANS 10142-1:2012

Edition 1.8

(As amended 2003, 2006 and 2012)

6.3.5 Prefabricated wiring

6.3.5.1 A prefabricated wiring system that is not wired on site shall allow for variation in building dimensions in such a way that the system, including the cables, is not subjected to any strain.

6.3.5.2 A prefabricated wiring system, especially any exposed cable ends, shall be protected against damage both during and after installation.

6.3.6 PVC insulated multicore cables with a bare earthing conductor and round cable with metal stiffening

6.3.6.1 The cables may be installed

- a) on the surface,
- b) under plaster,
- c) under a raised floor,
- d) in hollows (such as in walls and partitions) (no additional protection being needed),
- e) in roof spaces,
- f) direct in the ground (see 6.4.4.2, unarmoured buried cables),
- g) outdoors or exposed to water (but unless the manufacturer proves that the cables can withstand ultraviolet radiation, the cable shall be out of sight of the sky), and
- h) under screed if protected by an earth leakage protection device with a rated earth leakage tripping current (rated residual current) $I_{\Delta n}$ not exceeding 30 mA. **Amdt 5**

6.3.6.2 These cables shall not be buried direct in concrete.

Amdt 3; amdt 5

6.3.7 Joints and terminations

6.3.7.1 Joints and terminations of cables, cores and conductors shall be made in accordance with manufacturers' instructions or the appropriate part of SANS 10198. Flexible cables shall only be joined using termination boxes, cable couplers or manufacturers' jointing kits. All joints **Amdt 8**

SANS 10142-1:2012

Edition 1.8

(As amended Jan. 2003, Mar. 2003 and 2012)

6.6.1.15 Switchgear shall be fully rated for withstanding the prospective short-circuit current that could occur at that point in the system, unless series-connected (cascaded) systems are applied in accordance with 6.7.4.

6.6.1.16 Where the prospective fault level of the supply cannot be determined, a fault current meter may be used (see 8.5.2).

6.6.1.17 All disconnecting devices in a distribution board

- a) shall be protected by a fully rated short-circuit protective device, and
- b) when used in combination with a short-circuit protective device (see 6.7.4), shall have a conditional short-circuit current rating (see 3.22.1) appropriate to its condition of installation, but of not less than 2,5 kA.

6.6.1.18 If an installation is likely to be extended, a distribution board with spare ways should be fitted.

6.6.1.19 Each unoccupied opening of a distribution board shall be fitted with a blanking plate.

6.6.1.20 Unless obvious, permanent labelling shall identify all incoming and outgoing circuits of the distribution board.

6.6.1.21 The following warning labels shall be fitted to all distribution boards:

- a) an indication of where the distribution board is fed from, except for single distribution board installations. (Where the supply is derived from sources other than the main supply, for example, generators or UPS, see 7.12.4.); **Amdt 1; tech. corr.**
- b) if the short-circuit rating exceeds 2,5 kA, the minimum fault current rating of switchgear that can be used;
- c) in the case of series-connected (cascaded) systems, the warning label required by 6.7.4(d);
- d) the current rating of the busbars shall be indicated where it exceeds 100 A; and **Amdt 8**
- e) a label that indicates the position where the readily accessible earthing terminal for the bonding of other services is provided (see 6.11.5). **Amdt 8**

SANS 10142-1:2006

Edition 1.5

(As amended 2003 and 2006)

6.6.1.22 The insulation-resistance test on wiring and components shall be performed in accordance with 8.7.8.

6.6.1.23 Deleted by amendment No. 3.

6.6.2 Busbars

6.6.2.1 Unless fully tested in accordance with SANS 60439-1/ IEC 60439-1, the current density of copper busbars shall not exceed 2 A/mm² for currents \leq 1 600 A, or 1,6 A/mm² for currents $>$ 1 600 A.

Amdt 1

6.6.2.2 The size and design of the busbar system shall be appropriate to the prospective short-circuit current that could occur at the supply terminals of the distribution board.

6.6.2.3 Where fishplates are used for busbar connections, the cross-sectional dimensions of the fishplates shall be similar to those of the busbar, and the overlap on each side shall be at least equal to the width of the busbar.

6.6.2.4 Standard colour coding, i.e. red, yellow, blue, or numbering L1, L2 and L3, shall be used to identify phase busbars. Green/yellow shall be used for the earthing busbar and black for the neutral busbar.

6.6.2.5 If colour is used for control wire coding, any colour may be used except green/yellow, green, or black.

6.6.2.6 In the case of a multiphase distribution board, the neutral busbar shall be at least 50 % of the cross-sectional area of the phase busbar provided that only particular application conditions permit such reduction. (For harmonics, see 6.2.11.)

Amdt 5

6.6.2.7 The cross-sectional area of the earthing busbar (protective conductor) shall be not less than the appropriate value shown in table 6.24(a).

Amdt 5

If the application of this table produces non-standard sizes, the nearest larger standard size shall be used.

Amdt 5

SANS 10142-1:2012

Edition 1.8

(As amended Jan. 2003, Dec. 2003, 2006, 2008 and 2012)

6.6.6 Alterations/extensions to distribution boards with a short-circuit rating above 10 kA **Amdt 3**

6.6.6.1 Alterations or extensions on site to distribution boards with a short-circuit withstand current above 10 kA shall comply with the requirements of 6.6.6.2, and where reports and similar documents are available, apply

Amdt 1; amdt 3; amdt 5

- a) the rules given in SANS 1973-1 or SANS 1473-1 for the maximum permissible deviations allowed for a PTTA, or **Amdt 5; amdt 6**
- b) the rules for derivations from the minimally tested ASSEMBLY as in SANS 1973-8 or from an STA as in SANS 1473-1. **Amdt 5; amdt 6**

6.6.6.2 When a distribution board is modified or extended, the following requirements shall apply: **Amdt 3**

- a) the mechanical and electrical integrity of the distribution board shall not be infringed;
- b) the integrity of the area in a distribution board or a section of a distribution board that comprises the conductors (including distribution busbars) between the main busbars and the supply side of functional units and the components included in these units, which is regarded as fault free on the basis of the reduced short-circuit stresses that occur on the load side of the prospective short-circuit protective device in each unit, is still applicable; **Amdt 3**
- c) extensions to the busbar systems shall not adversely affect the electrical and mechanical performance of the complete busbar system;
- d) components shall be selected for their suitability for application taking into account information available from the component manufacturers. It might be necessary to derate the components depending upon environment and application conditions; **Amdt 3**

SANS 10142-1:2012

Edition 1.8

(As amended Jan. 2003, Dec. 2003 and 2012)

WARNING

Do not replace any component in the system with a component that is not of identical type and rating except when recommended by the manufacturer of the existing component, or the manufacturer of the distribution board, or a person competent to express an opinion on such replacement.

Amdt 8

e) any changed properties due to alteration or extension of the distribution board shall be marked indelibly on a supplementary nameplate; and

Amdt 3

f) the required IP rating shall not be reduced.

Amdt 3

SANS 10142-1:2012

Edition 1.8

(As amended 2003, 2006, 2008 and 2012)

emergency lighting, a deep-freeze, a burglar alarm, data processing equipment, or life-supporting equipment); **Amdt 5; amdt 8**

- c) circuits that supply fixed socket-outlets positioned out of normal reach, rated at less than 16 A and intended for the connection of luminaires (see 6.14.1.4); and
- d) a stove coupler that complies with SANS 60309-1/IEC 60309-1 and of dimensions as given in SANS 337 (see 6.15.1.2.5). **Amdt 5**

6.7.5.6 A warning label shall be fitted to every socket-outlet circuit where

Amdt 5

- a) the rated earth leakage tripping current (rated residual current) $I_{\Delta n}$ is higher than 30 mA, or **Amdt 3; amdt 5**
 - b) the socket-outlet circuit is powered from a safety supply, or **Amdt 5**
 - c) the socket-outlet circuit is on dimmer control, **Amdt 5**
- indicating such tripping current, safety supply or dimmer control. **Amdt 5**

6.7.5.7 An earth leakage protection device that is not provided with integral overcurrent protection

- a) shall be protected by a fully rated short-circuit protective device, or
- b) when used in combination with a short-circuit protective device, shall have a conditional short-circuit current rating (see 3.22.1) appropriate to its condition of installation, but of not less than 2,5 kA.

6.7.6 Surge protection

6.7.6.1 Surge protective devices (SPDs) may be installed to protect an installation against transient overvoltages and surge currents such as those due to switching operations or those induced by atmospheric discharges (lightning). **Amdt 1; amdt 6**

NOTE SPDs installed for lightning protection will automatically cover switching surges. **Amdt 6**

6.7.6.2 Where SPDs are to be installed in low-voltage installations, their selection, connection and application shall be in accordance with SANS 61643-12/IEC 61643-12 and annex L.1. **Amdt 6**

NOTE A risk assessment analysis may be performed in accordance with SANS 62305-2/IEC 62305-2 and annex L.2. **Amdt 6**

Pages 170 to 173 have been deleted by amendment No. 1.

SANS 10142-1:2003

Edition 1.1

This space is intentionally left blank

6.8 Circuit-breakers

6.8.1 Circuit-breakers used as main or local switch-disconnectors

A circuit-breaker that is used as a main or local switch-disconnector (see 6.9.4) shall comply with the relevant requirements of a standard given in clause 4 for switch-disconnectors, or, alternatively, a switch-disconnector shall be positioned on the supply side of the circuit-breaker.

6.8.2 Circuit-breakers used as switches

6.8.2.1 A circuit-breaker that is used as a switch (for example, as a protective device for a socket-outlet) shall comply with the requirements of standards for both circuit-breakers and switches.

6.8.2.2 Except for a circuit-breaker that is mounted next to the appliance or socket-outlet that it controls, each circuit-breaker shall be labelled to show which circuit or appliance it controls.

SANS 10142-1:2012

Edition 1.8

(As amended 2003, 2008 and 2012)

- b) another device may be used instead of a switch-disconnector, where specified in this part of SANS 10142 for a particular application.

NOTE 1 Any switch used to control an inductive load has to be suitable for that duty.

NOTE 2 Unless the device is a switch-disconnector, it shall be marked.

NOTE 3 The removal of a plug from a socket-outlet is a means of safe disconnection.

Amdt 3

6.9.4 Main switch-disconnectors

The main switch-disconnector on each distribution board shall be easily accessible. (See also 6.6.1.1(b), 6.6.1.1(c), 6.6.1.6 and 6.6.1.9.) If, owing to the nature of the installation, it is necessary to be able to interrupt the supply immediately, the switch-disconnector shall be so installed that it can be rapidly identified and operated.

Amdt 8

6.10 Fuses

6.10.1 Fuses, other than fuses incorporated in an appliance or in a socket-outlet, shall not be installed in final circuits of a residential installation.

6.10.2 Where fuses are installed, they shall, except as allowed in 6.10.3, be installed in a distribution board and shall not be of the rewirable type.

6.10.3 Fuses that are not installed in a distribution board shall be

- a) of the fully shrouded type, or
- b) in a suitable protecting case, or
- c) incorporated in an appliance or in a socket-outlet, or
- d) incorporated in a switch or in controlgear.

6.10.4 Fuse-protected circuits shall be marked with the maximum permissible current rating.

6.11 Consumer's earth terminal

6.11.1 Each installation shall have a consumer's earth terminal (see 3.18) at or near the point where the supply cables to the installation enter the building or structure. All conductive parts that are to be earthed (see 6.12.3) shall be connected to a main earthing terminal (see 3.29.4), which shall be connected to the consumer's earth terminal. The consumer's earth terminal shall be earthed by connecting it to the supply earth terminal (see 3.78) or the protective conductor (see 3.15.8) and, if installed, the earth electrode. The

Amdt 6

SANS 10142-1:2008

Edition 1.6

(As amended 2008)

effectiveness of the supplier's protective conductor shall be determined in accordance with 8.7.5.

6.11.2 In every installation where main equipotential bonding is used, the following shall be connected to the main earthing terminal in the distribution board: **Amdt 6**

- a) main equipotential bonding in accordance with 6.13;
- b) earthing conductors;
- c) bonding conductors, except for supplementary equipotential bonding conductors for medical locations in accordance with 7.7.4.6;
- d) functional earthing conductors (for example, those given in annex N, if relevant);
- e) conductive screens, sheaths or armouring of telecommunication cables or telecommunication equipment;
- f) earthing conductors for overvoltage protective devices (including conductors of lightning protection systems);
- g) earthing conductors of radio communication antenna systems; and
- h) the earthing conductor of an earthed d.c. power supply system for information technology equipment.

NOTE The main earthing terminal of the building can generally be used for functional earthing purposes. (A foundation earth is regarded as the most effective earthing.)

6.11.3 If, for practical reasons, the supply to the installation cannot be automatically disconnected by an earth fault current double the rated current (or higher) of the main protective device, as an alternative, an earth fault detection and disconnecting device may be installed at the supply of the installation. The earth fault detection and disconnecting device shall be so installed that it operates at a current related to the earth loop impedance which will limit prospective touch voltages under short-circuit fault conditions to 25 V for a period not exceeding 5 s. This alternative does not relieve the supplier from the responsibility of providing a supplier's earth terminal (see SANS 10292).

6.11.4 Each conductor connected to the main earthing terminal shall be able to be disconnected individually. This connection shall be disconnectable only by means of a tool, shall be mechanically strong, and shall ensure the maintenance of electrical continuity.

SANS 10142-1:2012

Edition 1.8

(As amended 2008 and 2012)

6.11.5 A readily accessible earthing terminal shall be provided for the bonding of other services such as a telephone, an audio or a video system, and the like, to a building. Such an earthing terminal shall be bonded to the consumer's earth terminal by a conductor of at least 6 mm² copper or

equivalent, and shall be identified by the earth symbol 

Amdt 6; amdt 8

NOTE Providers of services other than the electrical power services should not access the distribution board or other parts of the electrical installation. **Amdt 6**

6.11.6 Labels shall be fitted to all distribution boards where the readily accessible earthing terminal for the bonding of other services is provided (see 6.6.1.21). **Amdt 8**

6.12 Earthing

NOTE 1 This subclause addresses earthing arrangements, earth continuity conductors and equipotential bonding in order to ensure the safety of the electrical installation. Functional requirements for information technology installations are addressed in annex N. Earthing arrangements may be used jointly or separately for protective and functional purposes according to the requirements of the electrical installation. Requirements for protective purposes always take precedence.

NOTE 2 The requirements for earthing arrangements are intended to provide a connection to earth that

- a) is reliable and suitable for the protective and functional requirements of the installation (for example, surge arresters, etc.),
- b) can carry earth fault currents, protective conductor currents and leakage currents to earth without danger from thermal, thermomechanical and electromechanical stresses and from electric shock that arise from these currents, and
- c) where relevant, is also suitable for functional requirements.

6.12.1 Earth continuity conductors

6.12.1.1 An earth continuity conductor shall

- a) consist of compatible conductors,
- b) if it forms part of a cable other than a flexible cable, comply with the relevant requirements of the standard for the cable,
- c) if it forms part of a flexible cable, be of the same material as, and have a nominal cross-sectional area at least equal to, that of the largest phase conductor,

SANS 10142-1:2008

Edition 1.6

(As amended 2008)

- d) if it does not form part of a cable or flexible cable, have a nominal cross-sectional area at least equal to that determined in accordance with table 6.28, as follows:
- 1) from the row of table 6.28 that gives the rated current of the overcurrent protective device, select a "length of earth continuity conductor" that most closely exceeds the actual length of the circuit;
 - 2) from the head of the column that gives the selected "length of earth continuity conductor", read off the minimum nominal cross-sectional area of earth continuity conductor to be used; and
- e) be able to carry the prospective fault current without excessive heating of the conductor, within the disconnecting time.

NOTE Where the armouring of a cable is used as the earth continuity path, the resistance of the earth continuity path shall not exceed the appropriate value given in table 8.1; it may be necessary to replace some of the steel wires with tinned copper ones or to use a supplementary earth continuity conductor.

6.12.1.2 Earth continuity conductors shall be so arranged that they cannot be tampered with.

6.12.1.3 A wireway shall not be used as an earth continuity conductor.

SANS 10142-1:2008

Edition 1.6

(As amended 2005 and 2008)

- d) fixings such as cleats, clips, saddles and clamps;
- e) equipment and appliances permanently connected to safety supplies;
- f) small parts such as screws or nameplates that are isolated by insulating material;
- g) structural steelwork, including items such as fire escapes and cat ladders; and
- h) metallic fittings in bathrooms if they are isolated from earth (see 7.1.5).

6.12.3.3 Metallic frames and metallic enclosures of electrical equipment shall be made electrically continuous.

6.12.4 Earthing of the neutral of combined sources

When an installation that has a common neutral is supplied from a combination of transformers and generators located near one another, the neutral terminal of each of these items shall be connected to a single neutral bar. This neutral bar shall be the only point at which the neutral of the installation is connected to the consumer's earth terminal except as in the case in 7.12.3.1.3.

Amdt 6

6.13 Bonding

NOTE 1 The aim of bonding is to bring all the bonded parts to the same electrical potential.

Amdt 4

NOTE 2 No external conductor is required if compliance with the requirements for continuity can be proved by the test in 8.7.2.

Amdt 4

6.13.1 Bonding conductors

A bonding conductor shall

- a) have a nominal cross-sectional area of at least 2,5 mm² copper or equivalent, and **Amdt 4**
- b) be so arranged that it cannot be tampered with. **Amdt 4**
- c) Text has been included in 6.13.2.4. **Amdt 4**

SANS 10142-1:2012

Edition 1.8

(As amended 2003, 2005, 2008 and 2012)

6.13.2 Parts to be bonded

6.13.2.1 General

The parts given in 6.13.2.2 to 6.13.2.5 shall be bonded.

6.13.2.2 Hot and cold water systems

Hot and cold water systems shall be bonded together and also be bonded to the earth continuity conductor system.

6.13.2.3 Antennas

The conductive components of an antenna structure (including a satellite dish) shall be bonded to the installation earthing system by means of a conductor of at least 2,5 mm² copper or equivalent.

Amdt 1; amdt 4; amdt 8

6.13.2.4 Roofs, gutters, down pipes and waste pipes

If a building is connected to an electricity supply, the roof(s), gutter(s), down pipe(s) and waste pipe(s) shall be bonded and earthed and the resistance of the earth continuity path shall not exceed 0,2 Ω, unless

Amdt 4

- a) the supply voltage does not exceed 50 V,
- b) the supply uses an underground service connection,
- c) the roof is made of, or covered with, non-conductive material,
- d) the gutter(s), down pipe(s) and waste pipe(s) are of non-conductive material, or
- e) the gutter(s) and down pipe(s) are attached to a metal roof that is covered with non-conductive material.

6.13.2.5 Water pumps

All accessible extraneous conductive parts associated with a water pump motor shall be bonded to the earth continuity conductor. These parts include the suction pipe, delivery pipe and pump casing.

6.13.2.6 Other services

Amdt 6

Other services such as water, gas, etc. in conductive material, which enter the premises, shall be bonded to the readily accessible

SANS 10142-1:2012

Edition 1.8

(As amended 2006, 2008 and 2012)

earthing terminal (see 6.11.5) by means of a conductor of cross-sectional area at least 2,5 mm² copper or equivalent. **Amdt 6**

NOTE 1 Providers of services other than the electrical power services should not access the distribution board or other parts of the electrical installation. **Amdt 6**

NOTE 2 Extraneous conductive parts of other services should not be used as an earth conductor. **Amdt 6**

6.14 Lighting

NOTE For extra low voltage lighting installations, see 7.9.

6.14.1 Lighting circuits

NOTE Where CFL lighting is installed, the rating of the conductors is based on double the sum of the lamp load, in watts (see 6.2.6.6 and 6.2.11.2.3). **Amdt 8**

6.14.1.1 A single-phase circuit that supplies luminaires only can supply any number of luminaires.

NOTE Without power-factor correction, a discharge lamp luminaire with magnetic ballast might have a current as much as 64 % higher than that of a power-factor corrected luminaire and would require bigger conductors and protection.

Amdt 6

6.14.1.2 Each identified group of single-phase luminaires supplied from a multiphase supply that also feeds other luminaires, shall be controlled by a local multiphase disconnecting device.

NOTE The disconnecting device should disconnect all live conductors that feed the group of luminaires, including the neutral, in order that maintenance work can be carried out without switching off all the lights.

6.14.1.3 A circuit that has two phase conductors and that supplies only luminaires that are connected between the phase conductors, may supply any number of points if

- a) the circuit is controlled by a multipole switch-disconnector, and
- b) any additional switches in the circuit are multipole switches.

SANS 10142-1:2008

Edition 1.6

(As amended 2008)

SANS 10142-1:2012

Edition 1.8

(As amended 2006, 2008 and 2012)

6.14.1.4 In a lighting circuit, a luminaire that is in a false ceiling or in a roof space 4 m above the floor where there is no ceiling, or in a floor cavity, or in a wall cavity, or in a similar position, may be fed from a socket-outlet which may be unswitched and not protected by earth leakage protection, provided that the socket-outlet

a) complies with SANS 164-3 or, except in the case of residential installations, with BS 1363-2 (for 13 A fused plugs), **Amdt 5**

NOTE As from 1 January 2011, in terms of the compulsory specification for plugs, socket-outlets and socket-outlet adaptors (see 2.1), BS 1363-2 socket-outlets may no longer be sold in South Africa. **Amdt 8**

b) supplies one luminaire only, not exceeding the rating of the socket-outlet,

c) is accessible for maintenance purposes, and

d) is within 3 m of the luminaire that it supplies.

6.14.1.5 A lighting circuit that incorporates 6 A socket-outlets or 13 A socket-outlets in accordance with 6.14.1.4 shall be protected by a circuit-breaker of not exceeding 20 A. Lighting circuits that incorporate 13 A (fused plug top) socket-outlets shall not be installed in a residential installation. **Amdt 5**

SANS 10142-1:2006

Edition 1.5

(As amended 2003 and 2005)

6.14.1.6 In a lighting circuit, a luminaire may be fed from a socket-outlet on a wall (that may be unswitched), provided that the socket-outlet

- a) complies with SANS 164-3, **Amdt 5**
- b) is protected by earth leakage protection,
- c) supplies one luminaire only, not exceeding the rating of the socket-outlet, and
- d) is within 3 m of the luminaire that it supplies.

At least one 16 A socket-outlet that complies with SANS 164-1 or SANS 164-2 (see 6.15.2.1) shall be installed in the same room. **Amdt 5**

6.14.1.7 If more than one phase in a lighting circuit is brought into one enclosure for switching purposes,

- a) labels (see 4.5) stating that the voltage between phase conductors could exceed 250 V shall be fixed in a visible position inside the enclosure (not on the cover plate); or **Amdt 1**
- b) the phase terminals in the enclosure shall be separated by suitable barriers.

NOTE To avoid nuisance tripping where earth leakage protection is used, it is advisable to restrict the number of discharge luminaires on a circuit.

6.14.1.8 If more than one circuit is brought into an enclosure, a warning label shall be fixed inside the enclosure.

6.14.2 Luminaires

6.14.2.1 Surface-mounted luminaires shall be selected and installed such that thermal damage to the mounting surface is avoided.

6.14.2.2 Ancillary equipment for luminaires (such as capacitors, chokes, resistors and transformers) shall be enclosed in

- a) a luminaire, or
- b) an enclosure that
 - 1) is non-flammable,

SANS 10142-1:2012

Edition 1.8

(As amended 2006, 2008 and 2012)

6.14.4.2 The outer contact of an Edison-screw type lamp holder shall be connected to the neutral conductor.

6.15 Socket-outlets

NOTE Earth leakage protection on socket-outlets is compulsory except where specified otherwise (see 6.7.5).

6.15.1 Construction

6.15.1.1 Deleted by amendment No. 3.

6.15.1.2 Dimensions

6.15.1.2.1 Except where otherwise specified in this part of SANS 10142, single-phase socket-outlets for general use (see also 6.14.1.4) shall

- a) be of the two-pole and earthing contact type, **Amdt 6**
Amdt 6
- b) comply with SANS 164-0, and **Amdt 6**
- c) have dimensions that comply with SANS 164-1 or SANS 164-2.

NOTE Socket-outlets specified in SANS 164-2 are preferred. **Amdt 6**
Amdt 8

6.15.1.2.2 Socket-outlets intended for the connection of industrial type equipment such as welding machines, shall conform to the dimensions given in SANS 1239. NOVA and DIN socket-outlets may only be fitted as replacement of, and in extension to, an installation where such socket-outlets exist.

6.15.1.2.3 Socket-outlets that supply caravans or boats shall conform to the dimensions given in SANS 1239 and shall have a six o'clock earthing position (see 7.6).

SANS 10142-1:2008

Edition 1.6

(As amended 2006 and 2008)

This page is intentionally left blank.

SANS 10142-1:2012

Edition 1.8

(As amended 2006, 2008 and 2012)

6.15.1.2.4 A socket-outlet that complies with SANS 164-4 may be used for the connection of appliances for critical application (such as emergency lighting, a deepfreeze, a burglar alarm, data-processing equipment, or life-supporting equipment). **Amdt 5; amdt 8**

NOTE 1 Dedicated socket-outlets are the only socket-outlets that need not be protected by earth leakage. **Amdt 5; amdt 8**

NOTE 2 Prevention of theft is not considered a critical application.

NOTE 3 The number of alternative socket-outlets is limited in the light of standardization. **Amdt 8**

6.15.1.2.5 A stove coupler shall comply with the requirements of SANS 60309-1 and shall be of dimensions as given in SANS 337. **Amdt 5**

6.15.1.2.6 A two-pole socket-outlet without earthing contact that has dimensions complying with SANS 164-2 or SANS 164-6 shall only be installed in a fixed installation when it is integrated with a socket-outlet complying with SANS 164-1 or SANS 164-2 with earthing contact in a multiple socket-outlet. **Amdt 6; amdt 8**

SANS 10142-1:2006

Edition 1.5

(As amended 2006)

NOTE 1 Earth leakage protection is not required for the stove circuit when a stove coupler is used.

NOTE 2 For a three-phase coupler, the earth connection needs special consideration.

6.15.1.3 Voltage

Socket-outlets that supply voltages other than the standard voltage shall

- a) have the voltage marked on them in a position that is visible after installation,
- b) be of a plug and socket system such that the socket-outlet cannot accept a plug in accordance with any part of SANS 164, and the plug cannot be plugged into a socket-outlet in accordance with any part of SANS 164; and **Amdt 5**
- c) in the case of SELV (below 50 V), comply with SANS 60906-3/ IEC 60906-3.

6.15.2 Rating

6.15.2.1 Socket-outlets shall be rated in accordance with the intended load. Unless otherwise allowed in this part of SANS 10142, socket-outlets rated at less than 16 A shall not be used in an electrical installation.

6.15.2.2 The anticipated load of a circuit that feeds socket-outlets shall not exceed 5 kW.

6.15.3 Single-phase circuits that only supply socket-outlets rated at 16 A

Single-phase circuits that only supply socket-outlets rated at not more than 16 A,

- a) shall have overcurrent protection;
- b) shall use conductors that are rated at not less than 16 A;
- c) shall, if the circuit protection is rated at more than 20 A, use only protected socket-outlets, with, as far as is practicable, discrimination between the protective devices for the circuit and the protective

devices associated with the socket-outlets. The protective device of a protected socket-outlet shall

- 1) have a fixed rated current that does not exceed the rating of the socket-outlet,
- 2) be mounted next to the socket-outlet that it protects,
- 3) provide protection against overload currents,
- 4) provide protection against short-circuit currents, unless short-circuit protection is provided by a separate device, for example on the distribution board,
- 5) if it needs the protection of a back-up short-circuit device, be marked with the required or maximum rating of the back-up device,
- 6) if it protects more than one socket-outlet, be so installed that all the socket-outlets are connected in parallel, have the same rated current, and are mounted next to the device, and
- 7) if it is a circuit-breaker, comply with the requirements of 6.8.2.

NOTE In the interests of safety, the use of the building, the convenience of the occupants and the possibility of heating and cooling equipment being connected to socket-outlets, should be considered when the number and position of points of consumption are being determined.

6.15.4 Mixed loading of circuits

6.15.4.1 Except as allowed in 6.15.4.2, 6.15.4.3 and 6.16.3.2.3, there shall be no mixed loading of circuits. **Amdt 5; amdt 8**

6.15.4.2 Except as required in 6.16, a non-dedicated single-phase circuit that has overcurrent protection rated at not more than 20 A may supply a mixed load of a combination of any socket-outlets rated at not more than 16 A, luminaires and fixed appliances. **Amdt 8**

NOTE 1 The number of points need not be limited but the diversity of loads should be considered. **Amdt 8**

NOTE 2 Mixed circuits should be carefully considered since this may result in nuisance tripping. **Amdt 8**

SANS 10142-1:2003

Edition 1.1

6.15.4.3 Socket-outlets rated at 16 A or more that are connected to circuits with mixed loading shall comply with the earth leakage requirements of 6.7.5.

NOTE 1 See 7.1 for the conditions under which a socket-outlet may be installed in a bathroom.

NOTE 2 See 6.16.1.6 for the conditions under which a socket-outlet may be used for the connection of fixed appliances.

6.15.5 Circuits that supply single-phase socket-outlets rated at more than 16 A, or that supply three-phase socket-outlets, or both

In a circuit that supplies single-phase socket-outlets rated at more than 16 A, or that supplies three-phase socket-outlets, or both, and that supplies more than one socket-outlet,

- a) single-phase and three-phase socket-outlets may be supplied from the same circuit; and
- b) the rating of the circuit protection shall not exceed 125 % of the rating of the lowest rated socket-outlet, or each socket-outlet that has a rating of less than that of the circuit protection shall be individually protected against overcurrent.

6.15.6 Positioning of socket-outlets

6.15.6.1 A socket-outlet that is exposed to the weather (or to the condensation, dripping, splashing or accumulation of water) shall have a rating of at least IP44 in accordance with SANS 60529/IEC 60529. The rating applies whether a plug is in or out.

NOTE The IP ratings are explained in annex J.

6.15.6.2 A floor-mounted socket-outlet (recessed or not) shall be so mounted that

- a) the floor can be cleaned or washed without the insulation resistance of the installation being affected, and
- b) there is no risk of live parts touching any floor covering used.

6.15.6.3 A socket-outlet shall not be installed within a radius of 2 m of a water tap (in the same room) unless the socket-outlet

SANS 10142-1:2012

Edition 1.8

(As amended Jan. 2003, Dec. 2003, 2004, 2005 and 2012)

- a) has earth leakage protection, or
- b) is connected to a safety supply.

6.15.7 General

6.15.7.1 A socket-outlet in a d.c. circuit shall be controlled by a switch that is fixed next to it. **Amdt 5**

6.15.7.2 Each socket-outlet connected in a ring circuit shall be marked as such.

6.16 Fixed appliances

6.16.1 General

NOTE The general requirements in 6.16.1.1 to 6.16.1.13 apply, except where otherwise required for specific cases. **Amdt 4**

6.16.1.1 Fixed appliances do not form part of the electrical installation other than their positioning in relation to the supply and the wiring carried out between different parts of the appliances. **Amdt 1**

6.16.1.2 Deleted by amendment No. 4.

6.16.1.3 The power supply to every fixed appliance, except luminaires, shall be supplied through

- a) a disconnecting device that disconnects both live conductors in a single-phase supply and all phase conductors in a multiphase supply, or **Amdt 3**
- b) a socket-outlet **Amdt 3**

that is directly accessible at all times that any person is exposed to such appliance while the supply is on. In the case of a remotely installed appliance, the position of the disconnecting device shall be indicated by means of a notice in close proximity to or on the appliance. **Amdt 3**

6.16.1.4 Where a fan or heater is included in a luminaire, the luminaire is regarded as a fixed appliance. If the luminaire circuit is protected by an earth leakage protection device that has a rated earth leakage tripping current (rated residual current) $I_{\Delta n}$ not exceeding 30 mA, a disconnector is not required (see 6.9.3.1). **Amdt 1; amdt 8**

SANS 10142-1:2003

Edition 1.1

(As amended 2003)

SANS 10142-1:2012

Edition 1.8

(As amended Jan. 2003 and Dec. 2003)

6.16.1.5 The disconnecting device shall be positioned **Amdt 3**

- a) within 1,5 m from the appliance, or
- b) in a distribution board (if the switch-disconnector is capable of being locked in the open position). **Amdt 3**

Even where a disconnecting device is on the appliance, a separate disconnecting device shall be provided in the fixed installation to allow for the total removal of the appliance. **Amdt 3**

NOTE A standard switch is not a switch-disconnector.

6.16.1.6 A socket-outlet shall supply only one fixed appliance. The use of flexible cords of length exceeding 3 m is not recommended. The reason for this recommendation is an endeavour to ensure operation of the overcurrent protective device. (But see also 6.14.1.4 for luminaires.) **Amdt 1**

SANS 10142-1:2012

Edition 1.8

(As amended 2006 and 2012)

NOTE 1 Subclause 6.7.5 requires a socket-outlet to be protected by earth leakage protection.

NOTE 2 If an appliance is installed in a bathroom, see table 7.1 regarding earth leakage protection.

6.16.1.7 Where a socket-outlet in accordance with SANS 164-1, SANS 164-2, SANS 164-3, or SANS 1239 is part of the appliance (built-in), the circuit shall be protected by overcurrent and earth leakage protection (see 6.15.) Socket-outlets in accordance with SANS 164-4 shall have overcurrent protection.

Amdt 5

6.16.1.8 Surface-mounted appliances shall be selected and installed in such a way that thermal damage to the mounting surface is avoided.

6.16.1.9 Unless part of the appliance or self contained in their own enclosure, control components of fixed appliances that form part of the fixed installation, including their input terminations and associated protective switchgear that are not mounted in the distribution board, shall be incorporated in a suitable enclosure(s) that comply with the requirements of 6.6.1 and 6.6.4. Enclosure(s) shall be

- a) non-flammable,
- b) located as near to the appliance(s) as is practicable,
- c) permanently installed,
- d) such that they cannot be opened without the use of a tool, and
- e) readily accessible.

6.16.1.10 The connections between circuit conductors and appliance conductors shall

- a) allow enough slack immediately behind the base of the appliance for easy handling, and
- b) in the case of a pre-wired appliance, be made using a connector.

NOTE PVC insulated conductors should not be used where the temperature of the conductor could exceed 70 °C, unless the conductors are shielded from heat sources.

6.16.1.11 The wiring between different parts of a fixed appliance that are installed separately is part of the fixed installation, even where it is supplied from a socket-outlet, unless such wiring is less than 3 m in length.

Amdt 8

SANS 10142-1:2012

Edition 1.8

(As amended 2005 and 2012)

Such wiring shall be protected by separate overload protection unless its current-carrying capacity is such that the circuit protection of the socket-outlet circuit will provide protection or that part of the appliance has built-in thermal overload protection.

NOTE Where the length of wiring exceeds 3 m, the impedance and the functioning of the protective devices need to be considered to satisfy the overcurrent protection requirements in this part of SANS 10142. **Amdt 8**

6.16.1.12 Flexible conduit may be used for the final connection to a fixed or stationary appliance but may not be used as the final connection to a portable appliance, unless it has been authorized for this use.

6.16.1.13 The earth continuity conductor shall be connected to the earthing terminal of fixed electrical appliances that

- a) are exposed to the weather or to the condensation, dripping, splashing or accumulation of water, or
- b) use water, such as cooking appliances, laundering and dishwashing machines, water heaters, garbage disposal units and air-conditioning equipment.

6.16.2 Water heaters

NOTE Water heaters include geysers, instantaneous water heaters including units for boiling water, and the like (see also 6.16.1). **Amdt 4**

6.16.2.1 All water heaters shall be bonded in accordance with 6.13.

6.16.2.2 Dedicated circuits shall be provided for water heaters and there may be more than one water heater on each circuit.

NOTE If a water heater is installed in a bathroom, see table 7.1 regarding earth leakage protection.

6.16.3 Cooking appliances

NOTE Cooking appliances include built-in stoves, oven hobs, and the like (see also 6.16.1). **Amdt 4**

6.16.3.1 Switch-disconnector

6.16.3.1.1 The circuit that supplies a cooking appliance through fixed wiring, a stove coupler (see 6.16.3.3), or an industrial type socket-outlet (see SANS 60309-1/IEC 60309-1), shall have a readily accessible switch-disconnector. The switch-disconnector may supply more than one appliance. **Amdt 4**

6.16.3.1.2 A switch-disconnector for a cooking appliance(s) shall

SANS 10142-1:2006

Edition 1.5

(As amended 2004 and 2005)

- a) be in the same room as the appliance(s),
- b) be at a height above floor level of not less than 0,5 m and not more than 2,2 m,
- c) preferably not be above the cooking appliance(s),
- d) be within 3 m of the appliance(s), but within 0,5 m of the appliance(s) if the switch-disconnector's purpose is not clearly indicated, and
- e) not be fixed to the appliance.

6.16.3.2 Cooking appliance circuits

6.16.3.2.1 A dedicated circuit(s) shall be provided for cooking appliance(s) that are rated at more than 16 A.

6.16.3.2.2 One circuit shall not supply more than one permanently connected cooking appliance, unless the appliances are in the same room.

6.16.3.2.3 A cooking appliance circuit may also supply one socket-outlet if the rating of the socket-outlet does not exceed 16 A and if the following are all contained in one control unit (see also 6.15.4.1): **Amdt 5**

- a) the socket-outlet;
- b) an earth leakage protection device including overcurrent protection for protecting the socket-outlet; and
- c) the switch-disconnector required for the cooking appliance (see 6.16.1).

NOTE The socket-outlet has to be protected against earth leakage so, unless the protection device (see (b) above) is in the control unit, the entire cooking appliance circuit has to be protected against earth leakage.

6.16.3.2.4 If a cooking appliance is connected by means of a stove coupler (6.16.3.3.1 (a)) or an industrial type socket-outlet (6.16.3.3.1(c)), the open end of the connector tube or socket-outlet shall point downwards. **Amdt 4**

6.16.3.3 Stove connection

6.16.3.3.1 A stove designed to be a free-standing appliance rated above 16 A shall be connected through **Amdt 4**

SANS 10142-1:2012

Edition 1.8

(As amended 2005, 2006 and 2012)

- a) a stove coupler which shall comply with SANS 60309-1/IEC 60309-1 and of dimensions as given in SANS 337 (a maximum of 45 A single-phase and 16 A per phase for three phase), or **Amdt 5**

NOTE 1 Earth leakage protection is not required for the stove circuit when a stove coupler is used.

NOTE 2 For a three-phase coupler, the earth connection needs special consideration.

- b) Deleted by amendment No. 1.

- c) a socket-outlet that complies with SANS 60309-1/IEC 60309-1 (industrial type) with 30 mA earth leakage protection, however, the use of industrial type socket-outlets is not recommended for stove connections.

6.16.3.3.2 Text has been renumbered and moved to 6.16.3.2.4.

Amdt 4

6.16.4 Heaters, appliances for space heating and for cooling

NOTE 1 Heaters include towel rail and mirror heaters, hair and hand dryers, and the like (see also 6.16.1). **Amdt 4**

NOTE 2 Appliances for space heating include fixed heaters (including air conditioners), underfloor, undertile, undercarpet, underplaster heating, and the like (see also 6.16.1). **Amdt 4**

NOTE 3 Appliances for cooling include extraction and ventilation fans, fans combined with luminaires, air conditioning, refrigeration and freezer units, and the like (see also 6.16.1). **Amdt 4**

6.16.4.1 Heating and cooling

6.16.4.1.1 Dedicated circuits shall be provided for fixed space heating and cooling (air-conditioning units) that are rated at more than 16 A. There may be more than one unit on each circuit and the power supply to each unit shall be controlled by a switch-disconnector.

6.16.4.1.2 A heater with exposed live parts shall be mounted out of arm's reach from a person standing on the floor or on the bath's edge (see figure 7.1.1). For disconnection, see 6.16.1.5. **Amdt 8**

6.16.4.2 Underfloor heating

Amdt 4

6.16.4.2.1 The circuit that supplies underfloor heating shall be protected by an earth leakage protection device that has a rated earth leakage tripping current (rated residual current) $I_{\Delta n}$ not exceeding 30 mA. **Amdt 5**

SANS 10142-1:2008

Edition 1.6

(As amended 2003, 2005, 2006 and 2008)

6.16.4.2.2 The cables used to terminate underfloor heating shall be **Amdt 4; amdt 5**

- a) metal sheathed, or
- b) double insulated, or
- c) cables with reinforced insulation. **Amdt 5**

6.16.4.2.3 Heating elements installed above the screed under a wooden floor or under a carpet shall be covered by a metallic sheath (screened), which shall be connected to earth. **Amdt 5; amdt 6**

6.16.5 Motors

NOTE Motors include the motors in automatic doors and gates, garbage disposal units, pumps (pool, fountain, spa, etc.), and the like (see also 6.16.1). **Amdt 4**

6.16.5.1 Motor protection and control **Amdt 1**

6.16.5.1.1 Deleted by amendment No. 1.

6.16.5.1.2 In addition to the requirements of 6.7, the circuit that supplies a motor shall have overcurrent protection unless the motor

- a) forms part of equipment that has built-in overcurrent protection, or
- b) has an integral thermal protector with an accessible reset button, or
- c) has an automatic resetting thermal protector and there is no likelihood of mechanical damage or of injury to persons when the motor restarts, or
- d) is of a high impedance type that can stall without overheating (such as the motor of an electric clock).

6.16.5.1.3 The overcurrent protective device shall

- a) have a tripping value that is as near to the full load rated current of the motor as is practicable,
- b) have sufficient time delay to allow the motor to start and accelerate under normal conditions,
- c) prevent a multiphase motor from continuing to operate under load if single phasing occurs, and
- d) in the case of an automatically controlled motor, have to be manually reset after operation before allowing automatic restarting of the motor.

6.16.5.1.4 Any manually operated device used to control a motor shall be readily accessible to the person who operates it.

SANS 10142-1:2003

Edition 1.1

(As amended 2003)

6.16.5.1.5 Each motor shall be supplied by a manually operated disconnecter or any other manually operated disconnecting arrangement such as a withdrawable circuit-breaker, a removable link, a fuse or by the removal of a plug from a socket-outlet, which provides at least the same isolating distance, for the sake of safety, as a disconnecter that is

Amdt 3

- a) readily accessible and mounted on or next to the motor, or
- b) visible from the motor, or
- c) lockable in the open position, or
- d) housed in a lockable enclosure other than a distribution board.

6.16.5.2 Submersible motors and motors liable to flooding

NOTE See 7.2.4.4 for pump motors used in pools, spas and fountains.

6.16.5.2.1 A submersible motor shall

- a) be supplied by suitable marine type flexible cable firmly attached to the motor,
- b) use a cable gland that has an efficient water seal, and
- c) be bonded to the earthing system of the installation.

NOTE A portable water pump can have a submersible motor.

6.16.5.2.2 Conductive parts associated with a water pump (such as the suction pipe, the delivery pipe and the pump casing) shall be bonded to the earth continuity conductor. In the case of a submersible borehole motor, the bonding to the delivery pipe shall be made above ground and within 300 mm of the collar that supports the pipe.

6.16.5.3 Motor starters

Except in the case of direct-on-line starting, a starter shall have an undervoltage release that opens the circuit if the supply voltage drops sufficiently to cause the motor to stop. When the supply voltage is restored to a value that would cause the motor to restart, and unexpected

SANS 10142-1:2012

Edition 1.8

(As amended 2003, 2005 and 2012)

restarting could cause injury to the operator of the motor, the starter shall have a means of preventing the motor from restarting, whatever the type of starter.

6.16.5.4 Water pump motors

All accessible extraneous conductive parts associated with a water pump motor shall be bonded to the earth continuity conductor. These parts include the suction pipe, the delivery pipe and the pump casing.

Amdt 1

6.16.6 Electric fences

NOTE An electric fence is deemed to be a machine or an appliance and not part of the electrical installation. See separation of the high-voltage earth electrode of the fence energizer from the earthing system of the electrical installation. See SANS 10222-3.

Amdt 1; amdt 8

6.16.7 Electrode water heaters, steam generators and boilers

NOTE See 6 16.1.

Amdt 4

6.16.7.1 An electrode water heater, steam generator or boiler shall be connected to the a.c. supply system only. The supply shall be controlled by a multipole circuit-breaker that disconnects all phase conductors and there shall be a switch-disconnector fitted close to, and visible from, the water heater, unless

Amdt 1

- a) the circuit-breaker is close to, and visible from, the water heater, or
- b) a control switch for isolating the supply is positioned close to the water heater and indicating lights are visible from the control switch, one indicating light showing the closed position of the circuit-breaker and one indicating light showing the open position of the circuit-breaker.

6.16.7.2 Each exposed conductive part shall be bonded to the cold-water inlet, and earthed.

6.16.7.3 Earth leakage protection shall be provided for the circuit that supplies an electrode water heater, steam generator or boiler. This protection shall be set to operate in the event of a leakage current exceeding 10 % of the current consumed by the appliance under normal conditions of operation. The characteristics of the circuit and of the earth return path shall be such that the earth leakage device will operate before the potential between earth and the shell of the steam generator or boiler exceeds 50 V, including under short-circuit fault conditions.

SANS 10142-1:2008

Edition 1.6
(As amended 2003 and 2008)

7.7.4.3 Protection by automatic disconnection of supply

In groups 1 and 2 medical locations, where automatic disconnection of supply is applicable, the conventional touch voltage U_L shall not exceed 25 V and disconnection time shall not exceed 0,2 s.

NOTE Disconnection of supply for overload and short-circuit conditions can be achieved by different design methods within the procedures of the general rules in order to comply with the required safety level.

7.7.4.4 TN systems

7.7.4.4.1 In groups 1 and 2 medical locations, the maximum disconnection time shall not exceed 0,2 s for all circuits and final circuits that supply fixed equipment.

7.7.4.4.2 In group 1 medical locations, final circuits for socket-outlets up to 16 A shall be protected by earth leakage protection devices with a rated earth leakage tripping current (rated residual current) $I_{\Delta n}$ not exceeding 30 mA. **Amdt 3; amdt 6**

7.7.4.4.3 In group 2 medical locations, protection by automatic disconnection of the supply by means of earth leakage protection devices that have a rated earth leakage tripping current (rated residual current) $I_{\Delta n}$ not exceeding 30 mA shall only be used on the following circuits: **Amdt 3**

- a) circuits for X-ray units;
- b) circuits for large equipment with a rated power exceeding 5 kVA;
- c) circuits for non-critical electrical equipment (non-life-support); and
- d) circuits for the supply of operating tables (alternative to medical IT systems of electricity supply).

7.7.4.4.4 Care shall be taken to ensure that simultaneous use of many items of such equipment connected to the same circuit cannot cause unwanted tripping of the earth leakage device.

7.7.4.5 Medical IT system of supply (isolated system) (insulation monitoring) **Amdt 6**

7.7.4.5.1 In group 2 medical locations, the medical IT system of electricity supply shall be used for circuits that supply medical electrical equipment and systems intended for life support or surgical applications and other electrical equipment located in the patient environment, excluding equipment listed in 7.7.4.4.

SANS 10142-1:2003

Edition 1.1

7.7.4.5.2 In the case of each group 2 medical location, at least one separate medical IT system of electricity supply is necessary. The medical IT system shall be equipped with an insulation-monitoring device that

- a) has an internal impedance of at least 100 k Ω ;
- b) has a test voltage not exceeding 25 V d.c.;
- c) is of a current, even under fault conditions, not exceeding 1 mA d.c.; and
- d) shall indicate, at the latest, when the insulation resistance has decreased to 5 k Ω . A test device shall be provided to test this facility to ensure that the alarm (audible and visual) (see 7.7.4.5.4) operates when the insulation resistance reaches 5 k Ω ;

7.7.4.5.3 An overload and high-temperature-monitoring device for the medical IT system transformer is recommended.

7.7.4.5.4 For each medical IT supply system, an audible and visual alarm system shall be arranged in a suitable place such that it can be permanently monitored by the medical staff. The alarm system shall incorporate the following components:

- a) a green signal lamp to indicate normal operation;
- b) a yellow or red signal lamp that signals when the minimum value set for the insulation resistance is reached. It shall not be possible for this light to be cancelled and disconnected; and
- c) an audible alarm that sounds when the minimum value set for the insulation resistance is reached. The audible signal may be silenced.

The visual signal shall revert to green and the audible alarm shall be automatically reset on the removal of the fault condition.

7.7.4.6 Supplementary equipotential bonding

7.7.4.6.1 In each group 1 and group 2 medical location, insulated supplementary equipotential bonding conductors shall be installed and connected to the equipotential busbar for the purpose of equalizing potential differences between the following parts located in the patient environment:

SANS 10142:2003

Edition 1.1

- d) medical electrical equipment used in group 2 medical locations that serves surgical and other measures of vital importance;
- e) electrical equipment for medical gas supply that includes compressed air, vacuum, anaesthetics exhaustion and also their monitoring devices; and
- f) fire detection, fire alarms and fire extinguishing systems.

NOTE 1 This list is not exhaustive.

NOTE 2 The responsible authority should define medical electrical equipment that requires a safety power supply.

7.7.6 Verification

The instructions for tests and verification given in (a) to (e) apply to the electrical safety of the installation in compliance with the requirements of this part of SANS 10142 and also to the functions and performance of safety devices. The tests shall be carried out before commissioning, after alterations or repairs, and before recommissioning. In each case, the date and result of the test, the measurement or verification shall be recorded (see 8.8.2):

- a) test the functioning of the insulation-monitoring devices of IT systems and the audible and visual alarm systems;
- b) verify the integrity of the components required in 7.7.4.6.3 for equipotential bonding;
- c) take measurements to verify that the supplementary equipotential bonding is in accordance with 7.7.4.6.1 and 7.7.4.6.2;
- d) measure the leakage current of the output circuit and of the enclosure of medical IT transformers in the no-load condition (see 7.7.5.1.3); and
- e) verify compliance with the requirements of 7.7.5.6 for safety power supply services.

7.8 Temporary installations

7.8.1 General

NOTE Temporary wiring is wiring for installations used for activities such as temporary amusement parks, fêtes, fairs, marquee, voting stations, exhibitions, shows and flea markets. Construction and demolition sites are not included (see 7.4).

SANS 10142-1:2012

Edition 1.8

(As amended Jan. 2003, Dec. 2003, 2009 and 2011)

7.8.1.1 Control and protective switchgear shall be placed in closed cabinets, which can only be opened by the use of a key, or a tool, except for the equipment designed and intended to be operated by uninstructed persons.

7.8.1.2 The electrical installation shall be inspected and tested (see 8.2.4) and a test report issued, together with a CoC, by the registered person each time after the electrical installation has been assembled on a new site. **Amdt 7**

7.8.2 Supplementary equipotential bonding

7.8.2.1 In locations used for animals, supplementary equipotential bonding shall connect all exposed conductive parts and extraneous conductive parts, which can be touched simultaneously, and the protective conductor of the installation.

7.8.2.2 If a metallic grid is laid in the floor, it shall be connected to the local supplementary bonding required for locations where animals are kept (see 7.5.2).

7.8.3 Isolation

7.8.3.1 Every separate temporary structure (indoor or outdoor) such as a vehicle, a stand, or a unit, intended to be occupied by one specific user and each distribution circuit that supplies such installation shall be provided with its own readily accessible and properly identifiable means of isolation. **Amdt 8**

7.8.3.2 Automatic supply disconnection of cables, which is intended to supply temporary structures, shall be provided at the origin of the cables to each sub-distribution board by earth leakage protection devices with a rated earth leakage tripping current (rated residual current) $I_{\Delta n}$ not exceeding 300 mA. These devices can provide a delay by using a device for discrimination with earth leakage protection devices that protect final circuits. **Amdt 1; amdt 3**

7.8.3.3 Except for emergency lighting, all final circuits for lighting and socket-outlets shall be additionally protected by earth leakage protection devices with a rated earth leakage tripping current (rated residual current) $I_{\Delta n}$ not exceeding 30 mA. **Amdt 3**

NOTE Discharge lighting shall be connected to single-phase circuits to avoid nuisance tripping of the earth leakage protection device.

SANS 10142-1:2012

Edition 1.8

(As amended 2003 and 2012)

d) bare wire extra low voltage lighting systems shall comply with SANS 60598-2-23/IEC 60598-2-23.

7.9.1.4 The rated output current of the SELV source (transformer or convertor) shall not exceed 25 A.

7.9.1.5 The secondary circuits of more than one transformer shall not be connected in parallel.

7.9.1.6 The fixed secondary circuit of a transformer or a convertor connected to a socket-outlet (see 6.14.1.4 and 6.16.1.11) is part of the electrical installation.

7.9.1.7 Metallic structural parts of buildings, for example, pipe systems or parts of furniture, shall not be used as live conductors.

7.9.2 Wiring systems

7.9.2.1 Current-carrying capacity

7.9.2.1.1 In an extra low voltage lighting circuit, conductors with the appropriate steady state current rating shall be used to allow for the high currents usually associated with extra low voltage types of light.

7.9.2.1.2 The sum of the current ratings of the secondary circuits shall not exceed 125 % of the transformer rating.

7.9.2.2 Length of circuit and size of conductor

7.9.2.2.1 Since voltage drop has an adverse effect on light output, the recommended maximum length of the SELV circuit between the source and the load and the minimum conductor size for the circuit are given in table 7.3 for different loads and voltages. **Amdt 1**

NOTE 1 It is recommended that each extra low voltage light be supplied by its own SELV source (transformer or convertor). **Amdt 1**

NOTE 2 The conductor size can be reduced when a ring circuit is used. **Amdt 1**

NOTE 3 The manufacturer's instructions may contain more stringent requirements for the length of the circuit between the ELV source and the lamp. **Amdt 8**

7.9.2.2.2 The size of the SELV circuit conductors shall be not less than 1,5 mm².

Table 7.3 – The recommended length of a SELV circuit between the source and the load and the minimum size of SELV conductors for different lighting loads and voltages

1	2	3	4	5	6	7	8	9
Single circuit lighting load	Length of circuit between the source and the load							
	Up to 1,5 m		Up to 2,5 m		Up to 5 m		Up to 10 m	
	Minimum conductor size mm²							
	Different circuit voltages							
VA	12 V	24 V	12 V	24 V	12 V	24 V	12 V	24 V
20	1,5	1,5	1,5	1,5	1,5	1,5	4	1,5
40	1,5	1,5	1,5	1,5	2,5	1,5	6	2,5
50	1,5	1,5	1,5	1,5	4	2,5	6	4
60	1,5	1,5	2,5	1,5	4	2,5	10	4
75	1,5	1,5	2,5	1,5	6	2,5	10	6
80	1,5	1,5	2,5	1,5	6	4	10	6
100	2,5	1,5	4	2,5	6	4	–	6
120	2,5	1,5	4	2,5	10	4	–	10
140	4	1,5	6	2,5	10	6	–	10
150	4	1,5	6	2,5	10	6	–	10
160	4	1,5	6	2,5	10	6	–	10

Amdt 1; amdt 3

SANS 10142-1:2012

Edition 1.8

(As amended 2003, 2006 and 2012)

7.9.3.2.2 Except as allowed in 7.9.3.2.4, each secondary circuit of a safety extra low voltage (SELV) supply source (transformer or convertor) shall have overcurrent protection (see 6.7.1 and 6.7.2). The overcurrent protection may be either by a common protective device, or a protective device for each SELV circuit. **Amdt 8**

NOTE A circuit-breaker installed in the secondary circuit is not regarded as a distribution board and may be installed in an accessible position in the roof space. **Amdt 5**

7.9.3.2.3 A protective device shall be readily accessible unless it is built into the supply source and is of the automatic resetting type.

7.9.3.2.4 Secondary overcurrent protection is not required where the maximum output of the SELV transformer is 50 VA, the secondary circuit conductor is at least 1,5 mm², not exceeding a length of 2,5 m, and at least one conductor and its terminals are insulated to prevent a short circuit. **Amdt 1**

7.9.3.3 Protection against fire risk

7.9.3.3.1 Mounting of luminaires

7.9.3.3.1.1 For the selection of luminaires with regard to their thermal effect on the surroundings, the following features shall be taken into account:

- a) the maximum permissible power dissipated by the lamps;
- b) fire resistance of adjacent material
 - at the point of installation; and
 - in the thermally affected areas; and
- c) minimum distance to combustible materials, including materials in the path of a spotlight beam.

7.9.3.3.1.2 Depending on the fire resistance of the material at the point of installation and in thermally affected areas, the manufacturer's installation instructions shall be followed. Marked luminaires shall be selected and installed according to the marking instructions.

7.9.3.3.1.3 At least 200 mm of the conductors leading from an ELV lamp holder shall be 180 °C (class H) flexible conductors such as silicon-rubber-insulated conductors. The lamp holder shall also be suitable for an operating temperature of at least 180 °C. **Amdt 3**

SANS 10142-1:2012

Edition 1.8

(As amended 2012)

7.9.3.3.1.4 The ELV power source shall not be installed above the lamp or within 200 mm from the lamp to any side unless a heat barrier is installed between the lamp and the power source.

7.9.3.3.2 Fire risk by short circuit

At least one conductor and its terminals, for the part of the circuit between the transformer and the protective device, shall be insulated to prevent a short circuit.

7.9.4 Position of components

7.9.4.1 Primary terminals of the supply source shall be in an enclosure.

7.9.4.2 Cables shall be fixed in such a way as to prevent strain on the terminals or connectors.

7.9.4.3 Any SELV sources with a mass of more than 1 kg shall be fixed.

7.9.4.4 Transformers, protective devices or similar equipment, which are mounted above ceilings or in a similar place, shall, as far as is reasonably practicable, be mounted on a fixed part of the building such as a beam.

Amdt 8

7.9.4.5 If the identification of a protective device for a circuit is not immediately evident, a sign or diagram (label) close to the protective device shall identify the circuit and its purpose.

7.10 Stage and theatre equipment

7.10.1 General equipment and wiring

7.10.1.1 Resistors and dimmers that generate heat shall be supported on, and, where necessary, enclosed in, non-flammable material. Ventilation shall be used to prevent them from overheating.

7.10.1.2 Equipment that generates heat in excess of the safe touch temperature (see 5.1.2) shall be inaccessible to the public.

7.10.1.3 See 7.13.7.2 concerning autotransformers.

7.10.1.4 Arc lamps, other than those in projectors, shall be controlled by a multipole switch mounted on the frame that supports them.

SANS 10142-1:2012

Edition 1.8

(As amended 2008 and 2012)

7.12.3.2 Additional requirements for installations that incorporate static uninterruptible power systems (UPS) equipment

7.12.3.2.1 The UPS shall be fitted with overcurrent protection devices designed to disconnect the output of the UPS in the case of overcurrent or earth faults that occur in the part of the installation supplied by the UPS. The earth loop impedance, including the internal impedance of the UPS, shall comply with the requirements of 8.7.5. **Amdt 8**

7.12.3.2.2 Where a common neutral and a bypass switch are used, the part of the installation supplied by the UPS shall be provided with earth leakage protection as required in 6.7.5. (See figure S.3.)(See also 6.7.5.5(a) for exclusion relating to safety supplies.) **Amdt 8**

7.12.4 Protection against overcurrent

7.12.4.1 Overcurrent protection and isolation shall be located as near as possible to the output terminals of each alternative supply unit, except where the cable connecting the unit to the distribution board is mechanically protected and is regarded to be within the fault-free zone of the distribution board where protection is installed. The circuit-breaker magnetic characteristic shall have a low threshold value in view of the high impedance in the case of a generator or of the current-limiting characteristics in the case of a static UPS. Downstream coordination shall take this into account. To be consistent with the rest of this part of SANS 10142, overcurrent protection is required for the protection of the conductors, but might also provide protection to the alternative supply unit. **Amdt 6**

7.12.4.2 Where a generating set is intended to operate in parallel with the main supply or where two or more generating sets may operate in parallel, circulating harmonic currents shall be limited so that the thermal rating of conductors is not exceeded. The effects of circulating harmonic currents can be limited by

- a) the selection of generating sets with compensated windings,
- b) the provision of suitable impedance in the connection to generator star position,
- c) the provision of switches which interrupt the circulatory circuit but are interlocked so that at all times protection is not impaired,
- d) the provision of filtering equipment, and
- e) other suitable means.

SANS 10142-1:2012

Edition 1.8

(As amended 2008 and 2012)

7.12.5 Additional requirements for installations where the generating set provides a supply as a switched alternative to the main supply (standby systems and UPS systems that incorporate bypass switching)

7.12.5.1 Precautions that comply with the requirements of 6.9.1 for disconnection shall be taken, so that the generator cannot operate in parallel with the main supply where the supply to the electrical installation is supplied by a supplier. **Amdt 6**

NOTE Suitable precautions can include

- a) an electrical, mechanical or electromechanical interlock between the operating mechanisms or control circuits of the changeover switching devices, or
- b) a system of locks with a single transferable key, or
- c) a three position break-before-make changeover switch, or
- d) an automatic changeover switching device with suitable interlock, or
- e) other means that provide equivalent security of operation.

7.12.5.2 A 16 A switched socket-outlet shall be provided supplied from a utility board not connected to the plant direct.

7.12.5.3 The control panel may be either set mounted or be a free standing cabinet. In either instance the cabinet shall be considered a control assembly (see 6.6.7).

7.12.6 Deleted by amendment No. 6.

7.13 High-voltage (HV) apparatus

NOTE 1 HV apparatus includes signs, electrostatic particle precipitation and the like. This subclause covers circuits (other than the internal wiring of apparatus) that operate at voltages exceeding 1 000 V and are derived from an installation of voltage not exceeding 1 000 V a.c.

NOTE 2 A voltage exceeding 1 000 V which is stepped up in a power installation is covered in SANS 10142-2. **Amdt 8**

7.13.1 Rating plates

Each transformer, reactor, voltage regulator, induction coil, capacitor, rectifier and convertor shall have a rating plate securely fixed to it. The rating plate shall give the rated power and the rated voltages.

SANS 10142-1:2012

Edition 1.8

(As amended Dec. 2003, 2009 and 2012)

8 Verification and certification

8.1 Deleted by amendment No. 3.

NOTE In South Africa, it is a statutory requirement that every user or lessor of an electrical installation shall have a valid Certificate of Compliance (CoC) for every such installation. A CoC will only be valid when it is accompanied by a test report in the format of the test report in 8.8.

Amdt 3; amdt 7

8.2 **Responsibility** (see 8.8.1, section 5 of the test report)

Amdt 7

8.2.1 **Design**

Section 5.1 of the test report provides for the designer of the electrical installation to verify that the design complies with the requirements of this part of SANS 10142.

Amdt 3; amdt 7

NOTE See SANS 10142-2 where part of an electrical installation is above 1 000 V.

Amdt 8

8.2.2 **Material specification/procurement**

Section 5.2 of the test report provides for the specifier/procurer to verify that the equipment specified/procured is in compliance with the requirements of this part of SANS 10142.

Amdt 3; amdt 7

8.2.3 **Construction**

Section 5.3 of the test report provides for the installer of the electrical installation to verify that the installation was constructed in accordance with the requirements of this part of SANS 10142.

Amdt 3; amdt 7

NOTE In South Africa, it is a statutory requirement that an approved Inspection Authority (AIA), or a defined competent person, or a person registered in the professional category in terms of the Engineering Profession Act, 2000 (Act 46 of 2000), ensures compliance from commencement to commissioning of an electrical installation where the intention is to supply five or more users from a new point of supply (Regulation 5(6) of the Electrical Installation Regulations, 2009, of the Occupational Health and Safety Act).

Amdt 8

SANS 10142-1:2012

Edition 1.8

(As amended Jan. 2003, Dec. 2003, 2009 and 2012)

8.2.4 Inspection and tests

Section 5.4 of the test report provides for the person who carried out the inspection and testing of the electrical installation as given in 8.6 and 8.7, if the results are acceptable, to verify that the installation complies with the requirements of this part of SANS 10142. **Amdt 3; amdt 7**

NOTE 1 If the test report covers an installation in South Africa that existed before the publication of this part of SANS 10142 and extensions made since then, sections 5.1 to 5.3 will cover the new extensions only and, in section 5.4, both blocks that refer to installations which existed before and after the publication of this part of SANS 10142 should be marked.

Amdt 3; amdt 7

NOTE 2 Under certain circumstances, the same person could be responsible for the entire installation and the same signature can appear up to four times on the report. If no signature appears in any of sections 5.1 to 5.3 of the test report, the signatory of section 5.4 takes that responsibility. **Amdt 7**

NOTE 3 Deleted by amendment No. 3.

NOTE 4 Deleted by amendment No. 3.

8.3 Installation characteristics (section 2 of the test report)

Amdt 7

Section 2 of the test report gives certain characteristics of the installation that are relevant to subsequent inspection and testing. Further details of the information needed to complete section 2 of the test report are given in 8.4 and 8.5. **Amdt 7**

8.4 Electricity supply system (see section 2 of the test report and annex M). **Amdt 7**

8.5 Prospective short-circuit current (see section 2 of the test report and 6.7.3). **Amdt 7**

8.5.1 Obtain the estimated prospective short-circuit current (PSCC) at the point of supply or control from the supplier of electricity. **Amdt 5**

NOTE In the case of existing installations, determine whether the transformer capacity has been changed, since such change can affect the PSCC and thus the required kA rating of the switchgear. **Amdt 1; amdt 8**

SANS 10142-1:2012

Edition 1.8

(As amended 2003, 2006 and 2012)

8.5.2 In the case of supply systems rated at not more than 250 V to earth, measure the PSCC at the point of control with a commercially available instrument (fault current meter). Before any instrument is connected, confirm that the instrument is rated for the applicable current rating, in particular where the current rating at the main switch disconnector exceeds 100 A or the PSCC is expected to exceed 10 kA.

Amdt 5; amdt 8

NOTE 1 Do not measure three-phase PSCC if the meter is not specifically designed for that purpose or for the capacity of supply (or both). In a balanced three-phase system, the three-phase value can be estimated by multiplying the single-phase value by 1.73.

Amdt 8

NOTE 2 Ensure that the instrument connections do not add impedance to the circuit measured.

Amdt 8

CAUTION Verify the suitability and accuracy of the PSCC instrument with the manufacturer.

Amdt 5; amdt 8

8.5.3 Information on three-phase PSCC can also be obtained from graphs, tables and computer programs, suppliers of equipment, or can be calculated using the following formula:

$$\text{PSCC} = \frac{V}{\sqrt{3} \times Z_{\text{total}}}$$

where

V is the phase-to-phase voltage, in volts;

Z_{total} is the total impedance of the upstream network, in ohms (including, for example, the source transformer impedance and the impedance of a phase conductor).

8.5.4 The source transformer impedance can be calculated using the following formula:

$$Z_{\text{transformer}} = \frac{V^2}{P \times 10^3} \times \frac{Z_{\%}}{100}$$

where

$Z_{\text{transformer}}$ is the source transformer impedance, in ohms;

P is the power of the transformer, in kilovolt amperes;

$Z_{\%}$ is the rated short-circuit impedance voltage of the transformer, expressed as a percentage.

SANS 10142-1:2003

Edition 1.1

8.5.5 A.C. circuits

In a.c. circuits the impedance of a phase conductor can be calculated using the following formula:

$$Z_{\text{conductor}} = \frac{L \sqrt{R^2 + X^2}}{1\,000}$$

where

$Z_{\text{conductor}}$ is the impedance of the phase conductor, in ohms;

L is the length of the cable, in metres;

R is the conductor resistance, in ohms per kilometre (see table E.1);

X is the conductor reactance, in ohms per kilometre (see table E.1).

NOTE This calculation gives practical and conservative results.

8.5.6 D.C. circuits

8.5.6.1 In d.c. installations where a back-up source of power is provided (such as a battery), all sources shall be taken into account when calculating the prospective short-circuit current (PSCC).

8.5.6.2 Obtain the estimated prospective short-circuit current of the rectifiers and d.c. generators from the suppliers of the equipment.

8.5.6.3 The prospective short-circuit current of batteries can be calculated using the following formula:

$$\text{PSCC} = \frac{E_B}{R_{\text{BBr}}} \text{ A}$$

where

E_B is the open-circuit voltage of the batteries; if this information is not known, then use

$$E_B = 1,05 \times U_{\text{NB}} \text{ V (where } U_{\text{NB}} = 2,0 \text{ V/cell);}$$

R_{BBr} is the total resistance of the upstream network, in ohms, including the internal resistance of the battery and the resistance of the conductors;

$$R_{BBr} = 0,9 \times R_B + R_{BL} + R_Y \ \Omega \text{ (see figure 8.1);}$$

R_B is the internal resistance of the battery;

R_{BL} is the resistance of the battery connections;

R_Y is the resistance of the conductors.

NOTE The internal resistance of the battery can be obtained from the manufacturer's data.

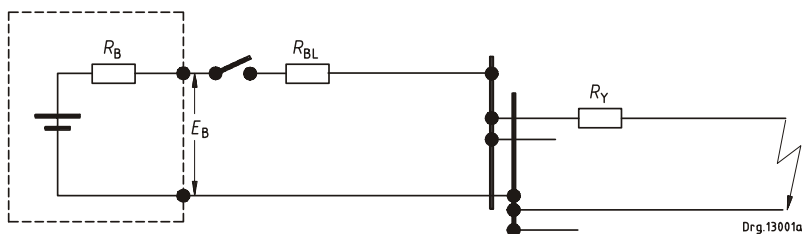

Figure 8.1 — Resistance components in a battery power source circuit

8.5.6.4 Alternatively the estimated PSCC at the battery terminals, as supplied by the manufacturer of the battery, may be used.

8.6 Inspection

8.6.1 Normally, inspection precedes testing and should be done with the installation isolated. Inspect the installation to confirm that equipment has been selected and installed in accordance with this part of SANS 10142 and that equipment is not damaged so as to impair its safety. **Amdt 8**

8.6.2 Complete the inspection table in the test report by confirming the statements with "Yes" in the appropriate block. "No" answers to any of the statements will prevent the issuing of the report. **Amdt 7**

8.6.3 During the inspection, confirm that **Amdt 8**

1) accessible components are correctly selected, **Amdt 8**

SANS 10142-1:2012

Edition 1.8

(As amended 2006 and 2012)

- 2) all protective devices are of the correct rating, **Amdt 8**
- 3) all protective devices are capable of withstanding the prospective short-circuit current, **Amdt 8**
- 4) conductors are of the correct rating and current-carrying capacity for the protective devices and connected load, **Amdt 8**

Pay attention to voltage rating, voltage drop, current-carrying capacity and short-circuit capacity.

- 5) components have been correctly installed, and are accessible where necessary, **Amdt 8**
- 6) disconnecting devices (isolators) are correctly located and that all switchgear switches the phase conductors, **Amdt 8**
- 7) different circuits are separated electrically. Circuits for control communication, security, detection, safety and the like, should be electrically separated and, where specified, physically separated, **Amdt 8**
- 8) connections of conductors and earthing and bonding are mechanically sound, **Amdt 8**
- 9) connections of conductors and earthing and bonding are electrically continuous, **Amdt 8**
- 10) circuits, fuses, switching devices, terminals, earth leakage units, circuit-breakers and distribution boards are correctly and permanently identified, marked or labelled, **Amdt 8**

Pay attention to installations where circuit-breakers are used in series-connected (cascaded) systems.

- 11) the integrity of the fire barrier has been maintained where an electrical system passes through a fire barrier, **Amdt 8**
- 12) safety lighting, emergency lighting and safety signs function correctly, **Amdt 8**

SANS 10142-1:2012

Edition 1.8

(As amended 2005, 2006, 2009 and 2012)

- 13)(a) in the case of new installations, or additions or alterations to existing installations, the new, added or altered installation complies with this part of SANS 10142, **or** **Amdt 8**
- 13)(b) in the case of installations that existed before the publication of this edition of this part of SANS 10142, the installation complies with the general safety principles of this edition of this part of SANS 10142 and is reasonably safe, **Amdt 5; amdt 8**
- NOTE Indicate (a) or (b) or (a) and (b) on the test report. **Amdt 8**
- 14) where an alternative supply is installed, it complies with all the requirements in 7.12, and **Amdt 8**
- 15) the position of the readily accessible earthing terminal for the earth connection of other services made by installers of such services (see 6.11.5) is indicated on all distribution boards (see 6.6.1.21(e)). **Amdt 8**

8.7 Testing

Certain tests shall not be carried out in hazardous locations. Due to the characteristics of the intrinsic safety features of equipment, such equipment can be damaged by certain tests. Certain tests might be impractical in existing installations already under power.

Amdt 5

8.7.1 General

NOTE Conduct all tests and complete a copy of "Section 4: Tests" for each distribution board and supply (normal and alternative supplies). **Amdt 8**

Additional tests may be required for large installations and where alternative supplies are installed. **Amdt 8**

For the testing of installations that are fully or partially in hazardous or specialized locations, see the relevant standards, and complete the additional report(s) (see 8.8.2 for medical locations and 8.8.3 for hazardous locations). **Amdt 7**

For cases where multiple tests are required, record the worst-case measurement on the test report. **Amdt 7**

In the case of failure in any test, the test shall be repeated after the fault has been rectified. Other tests that might have been influenced by the fault shall also be repeated.

Measuring instruments shall be accurate to within 5 % or better.

SANS 10142-1:2012

Edition 1.8

(As amended 2003)

8.7.2 Continuity of bonding**Amdt 4**

Test the continuity of the bonding between the consumer's earth terminal and all exposed conductive parts using a supply that has a no-load d.c. or a.c. voltage of 4 V to 24 V, and a current of at least 0,2 A. In each case, the resistance shall not exceed 0,2 Ω .

Amdt 4**8.7.3 Resistance of earth continuity conductor**

Use a resistance meter to measure the resistance of the earth continuity conductors between the consumer's earth terminal and the earthing terminals of all points of consumption and switches. The values shall not exceed those given in table 8.1.

Table 8.1 — Maximum resistance of earth continuity conductor

1	2
Rated current of protective device	Maximum resistance of earth continuity path
A	Ω
6,3	1,7
10	1,1
16	0,70
20	0,55
25	0,53
32	0,41
40	0,33
50	0,26
63	0,24
80	0,19
100	0,14
125	0,12
160	0,096
200	0,077
250	0,062
315	0,049
NOTE	In the case of metallic roofs, gutters, down pipes and waste pipes (see 6.13.2.4), the resistance of the earth continuity path shall not exceed 0,2 Ω .

All socket-outlets shall be tested by inserting a plug and including the resistance of the earth pin in the measurements.

8.7.4 Continuity of ring circuits

Remove both ends of each live conductor, separate them and test the circuit for continuity. Ensure that the two ends of the live conductor are connected to the same terminal after the test (see 6.6.1.13).

8.7.5 Earth fault loop impedance at the main switch

8.7.5.1 At the main switch, the impedance shall be such that an earth fault current double the rated current (or higher) of the main protective device automatically disconnects the supply to the installation. Table 8.2 indicates the earth fault loop circuits for different distribution systems.

Table 8.2 — Earth fault loop circuits for different distribution systems

1	2	3	4	5	6
Electricity supply system earthing	Earth fault loop circuit				
	Source	Phase	PEN	PE	Return through earth (soil)
TN-C-S (Figure M.2.1)	X	X	X		
TN-S (Figure M.2.2)	X	X		X	
TT (Figure M.2.3)	X	X			X
NOTE 1 The items marked X form the loop for the particular supply system earthing.					
NOTE 2 The TT system relies on a low-impedance earth both at the source transformer and at every consumer's installation. This system is impractical in most parts of Southern Africa due to high soil resistivity and conductor losses. It has the added disadvantage that the loss of earth connection is not inherently self-monitoring. The system is not recommended for use in South Africa.					

8.7.5.2 If, for practical reasons, the requirement in 8.7.5.1 cannot be complied with, as an alternative, an earth fault detection and disconnecting device may be installed at the supply to the installation. The earth fault detection and disconnecting device should be so installed that it operates at a current related to the earth fault loop impedance which will limit touch voltages to 25 V under short-circuit fault conditions for a period not exceeding 5 s.

8.7.6 Elevated voltage on supply neutral

With the main switch off, measure the voltage between the supply neutral and any earth external to the installation. Notify the supplier if the reading exceeds 25 V.

SANS 10142-1:2012

Edition 1.8

(As amended 2003 and 2012)

Disconnect the installation and notify the supplier (see annex K) if the reading exceeds 50 V.

8.7.7 Earth resistance

8.7.7.1 Earth resistance can be determined in accordance with SANS 10199. **Amdt 1; amdt 8**

Where the supplier does not provide an earthing terminal or where an alternative supply is installed, the efficiency of the earthing system can be confirmed by this test in SANS 10199. **Amdt 8**

8.7.7.2 Where the supplier provides an earthing terminal, this test is optional. **Amdt 8**

8.7.8 Insulation resistance

NOTE 1 Before power is connected to any new or altered circuit, the test for insulation resistance should be carried out to ensure there is no short-circuit or high impedance faults in the installation, and that it is safe to energize. **Amdt 8**

NOTE 2 In the case of existing installations where the power may not be switched off from certain circuits in order to carry out this test, the fact that the circuits are subject to the supply voltage can be regarded as evident that the insulation resistance is compliant. **Amdt 8**

WARNING: Special precautions are required for medical locations and in hazardous locations (see 7.7 and 7.14).

8.7.8.1 When carrying out insulation-resistance tests,

- a) use an a.c. or d.c. voltage of at least twice the nominal voltage, with a minimum of 500 V,

NOTE The working voltage is taken as the maximum of the voltages measured

- a) in the case of a.c., between each phase conductor and either the neutral or the earthing conductor, and
- b) in the case of d.c., between positive and negative conductors.

SANS 10142-1:2012

Edition 1.8

(As amended 2003, 2009 and 2012)

- b) ensure that all fuses are in place and switches and circuit-breakers are in the closed positions. Loads may be disconnected.

NOTE To prevent damage, ensure that voltage-sensitive electronic equipment such as dimmer switches, touch switches, time delay devices, power controllers, electronic starters for fluorescent lamps, earth leakage units, surge arresters and certain appliances are disconnected so that they are not subjected to the test voltage.

8.7.8.2 The insulation resistance, measured as follows, shall be at least 1,0 M Ω :

- a) to measure the insulation resistance to earth, apply the test voltage between the earth continuity conductor and the whole system of live conductors, or any section of it; and
- b) to measure the insulation resistance between the conductors, apply the test voltage
 - 1) between the phase conductors, and, when relevant,
 - 2) between the phase conductors and the neutral conductor.

8.7.8.3 When there are sub-distribution boards and the total insulation resistance is less than 1,0 M Ω , the insulation-resistance test may be carried out by

- a) isolating and testing the wiring between the main supply and the sub-distribution boards, and
- b) testing, as a separate section, each sub-distribution board connected to all the circuits that it feeds, but the insulation resistance in each section shall be at least 1,0 M Ω .

8.7.9 Voltage, main distribution board — no load

With all load switched off, measure the voltage at the point of control. Notify the supplier (see annex K) if the voltage is outside the standard voltage limits (see 5.3.2).

8.7.10 Voltage, main distribution board — on load

Switch on the maximum available load (see 8.7.11) and measure the voltage at the point of control. Notify the supplier (see annex K) if the voltage is outside the regulatory limits (see 5.3.2).

Amdt 8

SANS 10142-1:2012

Edition 1.8

(As amended 2003, 2009 and 2012)

8.7.11 Voltage at available load

Select the circuit and point of consumption where the worst voltage drop condition is expected. Switch on the maximum available load, but at least 50 % of the circuit load and not less than 2 A, and measure the voltage at that point of consumption. Record the value on the test report. The voltage drop from the point of supply to the point of consumption shall not exceed 5 % (see annex E). **Amdt 7; amdt 8**

8.7.12 Operation of earth leakage units

Ensure that earth leakage protection is installed in each circuit that is required to be so protected. At various points of outlet and for each phase conductor of the outlet, pass an a.c. leakage current equal to the rated earth leakage tripping current (rated residual current) $I_{\Delta n}$ through a resistance connected between a phase conductor and the earth continuity conductor. The circuit is protected if the earth leakage unit trips. **Amdt 3**

Repeat the test with a leakage current at 50 % of the rated earth leakage tripping current (rated residual current) $I_{\Delta n}$. The earth leakage unit shall not trip. **Amdt 3**

NOTE This test can be carried out only after power is available at the point of supply.

8.7.13 Earth leakage test button

Press the test button to see that the unit trips.

NOTE The test is intended to check whether the earth leakage unit is operating correctly, not to check its sensitivity.

8.7.14 Polarity at points of consumption

Ensure that

- a) all single-pole switching devices, fuses and circuit-breakers have been connected in the phase conductor,
- b) the phase terminals in fixed appliances and in all single-phase socket-outlets have been connected to the phase conductor,
- c) the centre contact of each Edison-screw lamp holder is connected to the phase conductor, and
- d) phase rotation and identification is maintained for three-phase systems on the supply sides of all distribution boards.

8.7.15 Switching devices

Ensure that when switching devices are operated, the circuit is interrupted as intended.

8.8 Test report

Amdt 7

8.8.1 Test report for all electrical installations

Amdt 7

The following is a test report for all electrical installations. This report may be supplemented with the additional test report for a medical location in 8.8.2 or the additional test report for a hazardous location in 8.8.3 (or both):

Amdt 3; amdt 7

SANS 10142-1:2012
Edition 1.8

Test report for all electrical installations

Amdt 7

CERTIFICATE OF COMPLIANCE (CoC) NO.	Date of issue:	
Additional pages added	<input type="checkbox"/> Yes	<input type="checkbox"/> No
TEST REPORT for ELECTRICAL INSTALLATIONS to SANS 10142-1		
<div style="border: 3px double black; padding: 2px; text-align: center;"> NOTE 1 In terms of South African legislation, the user or lessor is responsible for the safety of the electrical installation </div> <p>NOTE 2 This report covers only the part of the installation described in section 3. NOTE 3 This report covers the circuits for fixed appliances, but does not cover the actual appliances, for example stoves, geysers, air conditioning and refrigeration plant and lights. NOTE 4 Medical and hazardous locations require additional test reports (see 8.8.2 and 8.8.3). NOTE 5 Enter the required information or tick the appropriate block.</p>		
SECTION 1 – LOCATION (Only required if not provided on Certificate of Compliance)		
Physical address: Name of building:		

Amdt 3; amdt 7; amdt 8

SANS 10142-1:2012
 Edition 1.8
 (As amended 2003, 2009 and 2012)

Test report (continued)

SECTION 2 – INSTALLATION

Existing certificate: No. Yes Date issued: Number:

Existing installation **Alteration/extension** **New installation** **Temporary installation**

Type of installation: Residential Commercial Industrial Common area for multiple users
 Other Describe

Type of electricity supply system:

TN-S TN-C-S TN-C TT IT

Supply earth terminal provided: Yes No

Characteristics of supply:

Voltage: 230 V 400 V 525 V Other:..... V
 Number of phases: One Two Three
 Phase rotation Clockwise Anticlockwise
 Frequency: 50 Hz Other:..... d.c.

Prospective short-circuit current at point of control (PSCC):
 How determined? Calculated Measured From supplier

Main switch type:

Switch disconnector (on-load isolator) Fuse switch Circuit-breaker
 Earth leakage circuit-breaker Earth leakage switch disconnector

Number of poles: Current rating: Short-circuit/withstand rating:

Rated earth leakage tripping current $I_{\Delta n}$: 30 mA Other
 Surge protection (see 6.7.6 and annex L): Yes No
 Is alternative power supply installed? (See 7.12.) Yes No
 Is any part of the installation a specialized electrical installation? Yes No
 If yes, complete additional test reports (see 8.8.2 or 8.8.3)

Is any part of the installation at a voltage above 1 kV? Yes No
 If yes, competent person to approve design and complete additional test reports (see 8.6.3 and SANS 10142-2)

Is this installation one of five or more on the same supply? Yes No
 If yes, name of the competent person who supervised the installation (see 8.2.3):

Amdt 1; amdt 3; amdt 5; amdt 6; amdt 7; amdt 8

Test report (continued)

SECTION 3 – DESCRIPTION OF INSTALLATION COVERED BY THIS REPORT

(Add additional pages, specification references or drawings (layout of installation on premises), etc., where applicable)

.....

.....

NUMBER OF CIRCUITS OR POINTS COVERED BY THIS REPORT

Circuits	Existing installation					New/altered/temporary installation				
	Main distribution board	Sub-distribution boards				Main distribution board	Sub-distribution boards			
Lighting circuits										
Lighting points										
Socket-outlet circuits										
Sockets-outlets										
Three-phase socket-outlet circuits										
Three-phase socket-outlets										
Socket-outlets for critical application circuits										
Socket-outlets for critical applications										
Mixed circuits (number of)										
Motor circuits										
Control circuits										
Air-conditioning circuits										
Motor-controlled assembly circuits										

Amdt 7; amdt 8

Test report *(continued)*

Transformer circuits:	Lighting																		
	Bell																		
	Other																		
Heating circuits																			
Fan circuits																			
Elevator/escalator circuits																			
Signage circuits																			
Fixed appliance circuits:	Cooking																		
	Geyser																		
	Pool pump																		
	Borehole pump																		
	Other																		
Earth leakage:	Main switch																		
	Only socket-outlets																		
Overhead busbars																			
Alternative power supply connections																			
Other circuits																			

Amdt 6; amdt 7; amdt 8

Test report (continued)

SECTION 4 – INSPECTION AND TESTS (new and existing installations)	Additional tests added	<input type="checkbox"/> Yes	<input type="checkbox"/> No	<input type="checkbox"/> N/A
Inspection		Existing installation	New/alterd/ temporary installation	
NOTE Answer "Yes" or "N/A". The report shall not be issued if any "No" answers appear.				
1	Accessible components are correctly selected			
2	All protective devices are of correct rating			
3	All protective devices are capable of withstanding the prospective fault level			
4	Conductors are of the correct rating and current-carrying capacity for the protective devices and connected load			
5	Components have been correctly installed			
6	Disconnecting devices are correctly located and all switchgear switches the phase conductors			
7	Different circuits are separated electrically			
8	Connection of conductors and earthing and bonding are mechanically sound.			
9	Connection of conductors and earthing and bonding are electrically continuous.			
10	Circuits, fuses, switches, terminals, earth leakage units, circuit-breakers, distribution boards are correctly and permanently marked or labelled			
11	Where an electrical circuit passes through a fire barrier, the integrity of the fire barrier has been maintained.			
12	Safety and emergency lighting and signs are functioning correctly			
13(a)	In the case of new installations, or additions or alterations to existing installations, the new, added or altered installation complies with this part of SANS 10142,			
or				
13(b)	In the case of installations that existed before the publication of this edition of SANS 10142, the installation complies with the general safety requirements in this edition of this part of SANS 10142 and is reasonably safe			
NOTE 1	Indicate (a) or (b) or (a) and (b) on the test report.			
NOTE 2	Indicate N/A in the case of (a) of (b), where applicable.			
14	Where an alternative supply is installed, it complies with the requirements in respect of connections, change-over switch and indicator.			
15	Is the position of the readily accessible earthing terminal for earth connections of other services by installers of such services (see 6.11.5) indicated on the distribution board (see 6.6.1.21(e))?			

Amdt 4; amdt 6; amdt 7; amdt 8

Test report (continued)

Tests Carry out all the tests for the main distribution board. Also conduct all tests and complete copies of the tests for each distribution board and for each supply (normal and alternative supplies), and attach as annexes to this report.	Units	Instrument	Reading/result	
			Existing installation	New/alterd/ temporary installation
1 Continuity of bonding	Ω			
2 Resistance of earth continuity conductor	Ω			
3 Continuity of ring circuits (if applicable)	–			
4 Earth loop impedance test: at main switch	Ω			
5 Prospective short-circuit current at point of control (PSCC) for sub-distribution boards. Indicate: : <input type="text" value="....kA"/> <input type="checkbox"/> Calculated <input type="checkbox"/> Measured <input type="checkbox"/> From supplier				
6 Elevated voltage between incoming neutral and external earth (ground)	V			
7 Earth resistance at electrode (if required)	Ω			
8 Insulation resistance	M Ω			
9 Voltage at main distribution board with no load for each phase to neutral	V			
10 Voltage at main distribution board with load (as calculated for full load) for each phase to neutral	V			
11 Voltage at available load (worst condition as calculated for full load) for each phase to neutral	V			
12 Operation of earth leakage units	mA			
13 Operation of earth leakage test button	–		correct	correct

Amdt 7; amdt 8

Test report *(continued)*

14 Polarity of points of consumption	–		correct		correct	
15 Phase rotation at points of consumption for three-phase systems	–		correct		correct	
16 All switching devices, make-and-break circuits	–		correct		correct	

Comments:

.....

.....

.....

Comments on parts of the installation not covered by this report:

.....

.....

.....

Amdt 7; amdt 8

SANS 10142-1:2012
Edition 1.8
(As amended 2012)

286(b)

Test report (continued)

SECTION 5 – RESPONSIBILITY

NOTE For existing installations, complete only 5.4. For new/alterd/temporary installations, if no signature appears in 5.1 to 5.3, the signatory of 5.4 takes responsibility. Where there are five or more installations on the same supply, a competent person signs 5.5.

5.1 DESIGN. I, being the person responsible for the DESIGN of the electrical installation, particulars of which are described in section 3 of this form, CERTIFY that the work for which I have been responsible, is to the best of my knowledge and belief in accordance with the relevant legislation. The extent of my liability is limited to the installation described in section 3 of this form.

For the DESIGN of the installation:

Name (in block letters): Position:
Address:.....
Signature :
Profession Registration No.(where applicable) Date:

5.2 MATERIAL SPECIFICATION/PROCUREMENT. I/We, being the person(s) responsible for the MATERIAL SPECIFICATION/PROCUREMENT for the electrical installation, particulars of which are described in section 3 of this form, CERTIFY that the equipment that I/we have procured, is to the best of my/our knowledge and belief in accordance with the relevant legislation. The extent of liability of the signatory is limited to the installation described in section 3 of this form.

For the MATERIAL SPECIFICATION/PROCUREMENT

Name (in block letters): Position: ...
For and on behalf of:..... Address:
Signature:
Date:

Amdt 1; amdt 7; amdt 8

Test report (continued)

5.3 CONSTRUCTION. I/We, being the person(s) responsible for the CONSTRUCTION of the electrical installation, particulars of which are described in section 3 of this form, CERTIFY that the work for which I/we have been responsible, is to the best of my/our knowledge and belief in accordance with the relevant legislation. The extent of liability of the signatory is limited to the installation described in section 3 of this form.

For the CONSTRUCTION of the installation:

Name (in block letters):

For and on behalf of contractor:.....

Signature: Date:

5.4 INSPECTION AND TESTS. I, being the person responsible for the INSPECTION AND TESTING of the electrical installation, particulars of which are described in section 3 of this form, CERTIFY that the inspection and testing were done in accordance with this part of SANS 10142, that the results obtained and reflected on this report are correct, and indicate

(for installation work performed since the publication of this part of SANS 10142), compliance with this standard, or

(for an installation that existed before the publication of this part of SANS 10142), that the installation complies with the general safety principles of this standard and is reasonably safe.

The extent of my liability is limited to the installation described in section 3 of this form.

Name of registered person: Registration certificate No.:
(in block letters)

Type of registration: Master installation electrician Installation electrician Single-phase tester

Signature: Date:

Tel.No.:

Amdt 1; amdt 7; amdt 8

Test report *(concluded)*

5.5 COMPLIANCE OF INSTALLATION FROM COMMENCEMENT TO COMMISSIONING. I..... being the person responsible to ensure that the electrical installation, particulars of which are described in section 3 of this form and which is one of five or more installations on the same supply, CERTIFY that the installation was done in accordance with SANS 10142-1.

<input type="checkbox"/> An Approved Inspection Authority for electrical installations	Chief Inspector's registration No.	
<input type="checkbox"/> A competent person as defined	Indicate competency:	
<input type="checkbox"/> A professionally registered person	Category of professional registration:	Registration No.
Name (in block letters): Signature: Date:	Address:	

Amdt 1; amdt 7; amdt 8

Table J.1 — International protection ratings — IP ratings

1	2	3	4	5	6	
First characteristic numeral			Second characteristic numeral			
Protection against solid foreign objects		Meaning for the protection of persons against access to hazardous parts with:		Protection against harmful ingress of water		
IP	Tests			IP	Tests	
				Meaning for the protection against water:		
0	No protection	Non-protected		0	No protection	Non-protected
1	Full penetration of 50 mm diameter of sphere not allowed. Contact with hazardous parts not permitted.	Back of hand		1	Protected against vertically falling drops of water	Vertical dripping
2	Full penetration of 12,5 mm diameter of sphere not allowed. The jointed test finger shall have adequate clearance from hazardous parts	Finger		2	Protected against vertically falling drops of water with enclosure tilted 15° from the vertical	Dripping up to 15° from the vertical
3	The access probe of 2,5 mm diameter shall not penetrate	Tool		3	Protected against sprays to 60° from the vertical	Limited spraying
4	The access probe of 1,0 mm diameter shall not penetrate	Wire		4	Protected against water splashed from all directions – limited ingress permitted	Splashing from all directions
5	Limited ingress of dust permitted (no harmful deposit)	Dust-protected	Wire	5	Protected against low-pressure jets of water from all directions – limited ingress permitted	Hosing jets from all directions
6	No ingress of dust	Dust-tight		6	Protected against strong jets of water, e.g. for use on ship decks – limited ingress permitted.	Strong hosing jets from all directions
				7	Protected against the effects of immersion between 150 mm and 1 m	Temporary immersion
			8	Protected against long periods of immersion under pressure > 1m	Continuous immersion	

SANS 10142-1:2012

Edition 1.8

(As amended 2009 and 2012)

Annex K
(informative)

Notification of a potential danger
(See 8.7.6 and 8.7.10)

To:
..... (The supplier)
.....

From:
..... (The registered person)
..... **Amdt 8**

During an inspection in terms of SANS 10142-1, *The wiring of premises – Part 1: Low-voltage installations*, performed at stand

No.
situated at
.....
.....

I,, Registration No. **Amdt 7**

found the following potential danger:

- ...Elevated voltage on neutral of V,
- ...Voltage not within limits V,
- ...Other

Signed: Date:

Annex S
(informative)

Amdt 1; amdt 3; amdt 6

Examples of emergency power installation configuration

S.1 Change-over switch connection where standby power feeds in at main supply

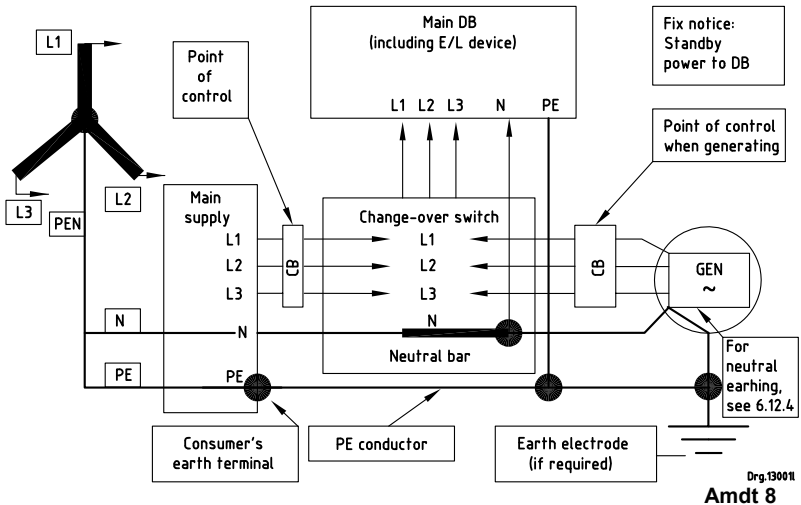

Key

CB	circuit-breaker	E/L	earth leakage
DB	distribution board	GEN	generator

NOTE 1 A three-pole change-over switch may be used where the supply is from a TN system of supply and the standby power is connected at the main supply. **Amdt 8**

NOTE 2 It may be necessary to break the neutral when neutral currents are present in the utility supply. **Amdt 8**

Figure S.1 — Change-over switch connection where standby power feeds in at main supply

SANS 10142-1:2012

Edition 1.8

(As amended Jan. 2003, Dec. 2003, 2008 and 2012)

S.2 Change-over switch connection where a standby power generator feeds into a section of the main distribution board
Amdt 6

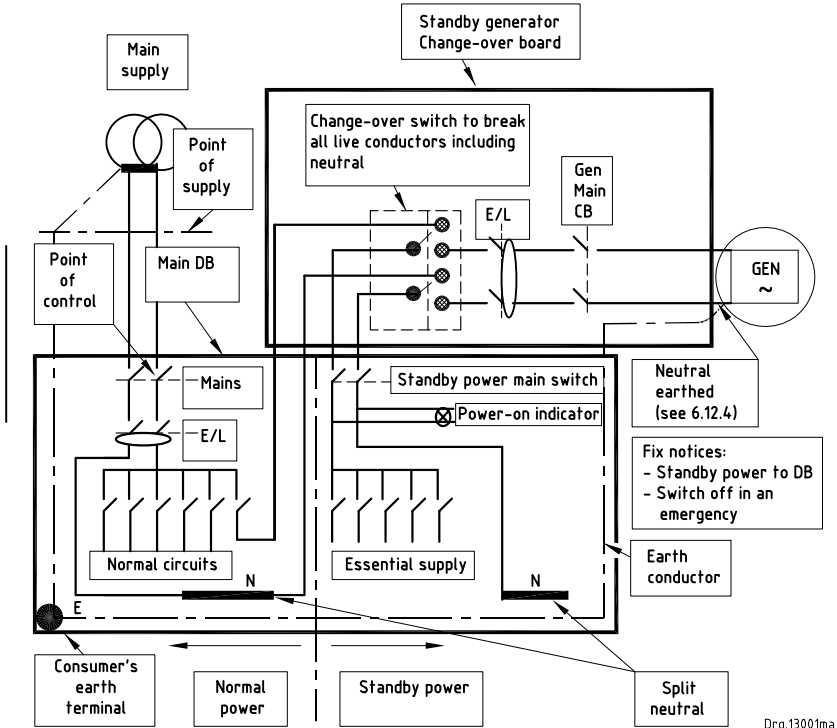

Drg.13001ma

Amdt 8

Key

CB	circuit-breaker	E/L	earth leakage
DB	distribution board	GEN	generator

NOTE See the split neutral bars.

The main switch may be an E/L device.

Figure S.2 — Change-over switch connection where a standby power generator feeds into a section of the main distribution board

S.3 Connection where UPS power feeds into a section of the main distribution board
 Amdt 6; amdt 8

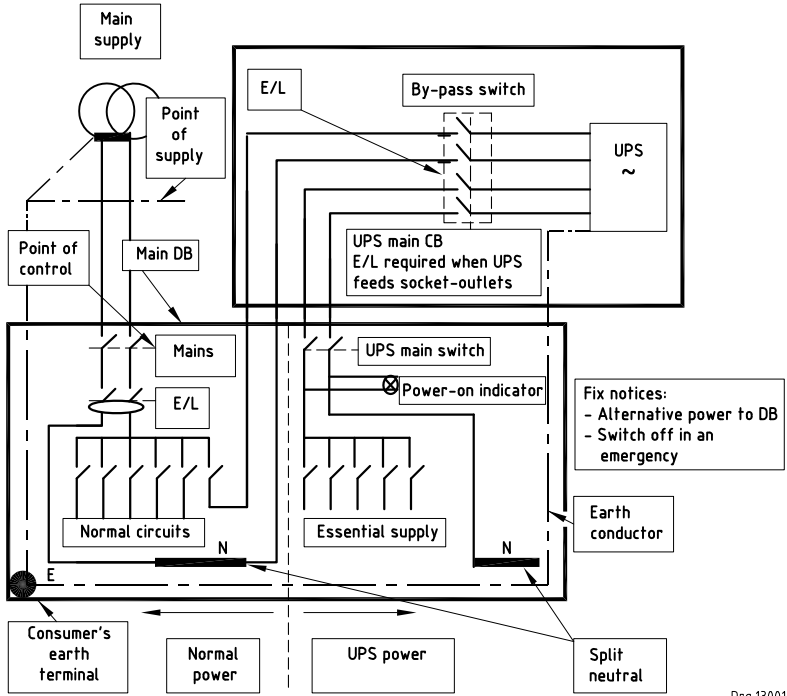

Drg.13001ha
 Amdt 8

Key

- CB circuit-breaker
- DB distribution board
- E/L earth leakage
- GEN generator

NOTE See the split neutral bars.

The main switch may be an E/L device.

Figure S.3 — Connection where UPS power feeds into a section of the main distribution board

Amdt 8

SANS 10142-1:2012

Edition 1.8

(As amended Jan. 2003, Dec. 2003, 2008 and 2012)

S.4 Change-over switch connection where standby power feeds in after the main distribution board (point of supply) into a sub-distribution board

Amdt 6

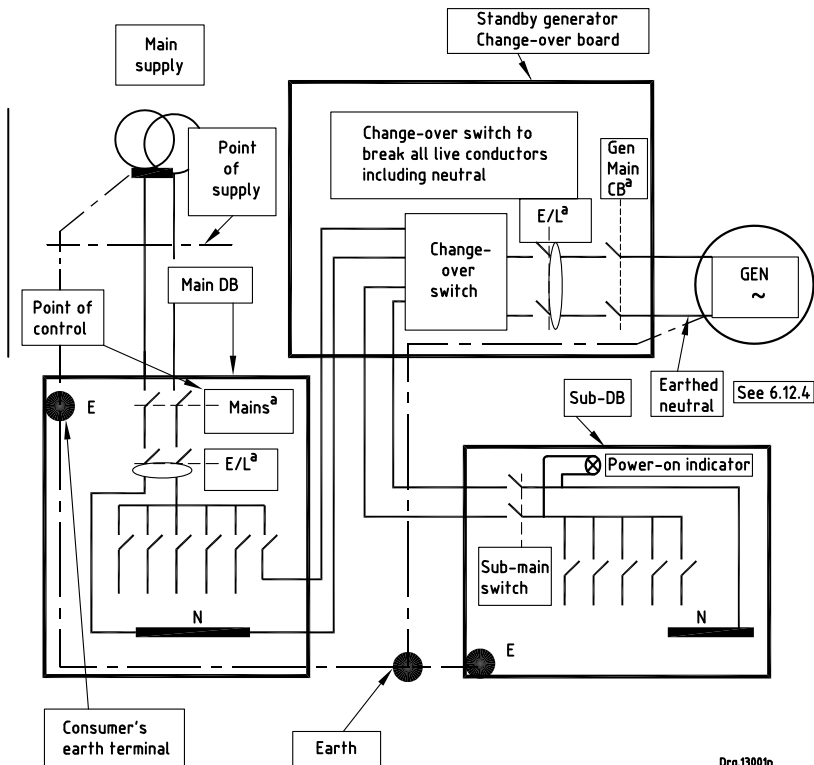

Org.13001n
Amdt 8

^a The main circuit-breaker may be an earth-leakage device with isolation function.

Figure S.4 — Change-over switch connection where standby power feeds in after the main distribution board (point of supply) into a sub-distribution board

© SABS

SABS – Standards Division

The objective of the SABS Standards Division is to develop, promote and maintain South African National Standards. This objective is incorporated in the Standards Act, 2008 (Act No. 8 of 2008).

Amendments and Revisions

South African National Standards are updated by amendment or revision. Users of South African National Standards should ensure that they possess the latest amendments or editions.

The SABS continuously strives to improve the quality of its products and services and would therefore be grateful if anyone finding an inaccuracy or ambiguity while using this standard would inform the secretary of the technical committee responsible, the identity of which can be found in the foreword.

Tel: +27 (0) 12 428 6666 Fax: +27 (0) 12 428 6928

The SABS offers an individual notification service, which ensures that subscribers automatically receive notification regarding amendments and revisions to South African National Standards.

Tel: +27 (0) 12 428 6883 Fax: +27 (0) 12 428 6828 E-mail: sales@sabs.co.za

Buying Standards

Contact the Sales Office for South African and international standards, which are available in both electronic and hardcopy format.

Tel: +27 (0) 12 428 6883 Fax: +27 (0) 12 428 6828 E-mail: sales@sabs.co.za

South African National Standards are also available online from the SABS website <http://www.sabs.co.za>

Information on Standards

The Standards Information Centre provides a wide range of standards-related information on both national and international standards, and is the official WTO/TBT enquiry point for South Africa. The Centre also offers an individual updating service called INFOPLUS, which ensures that subscribers automatically receive notification regarding amendments to, and revisions of, international standards.

Tel: +27 (0) 12 428 6666 Fax: +27 (0) 12 428 6928 E-mail: info@sabs.co.za

Copyright

The copyright in a South African National Standard or any other publication published by the SABS Standards Division vests in the SABS. Unless exemption has been granted, no extract may be reproduced, stored in a retrieval system or transmitted in any form or by any means without prior written permission from the SABS Standards Division. This does not preclude the free use, in the course of implementing the standard, of necessary details such as symbols, and size, type or grade designations. If these details are to be used for any purpose other than implementation, prior written permission must be obtained.

Details and advice can be obtained from the Senior Manager.

Tel: +27 (0) 12 428 6666 Fax: +27 (0) 12 428 6928 E-mail: info@sabs.co.za